

# PARTS PRICE LIST

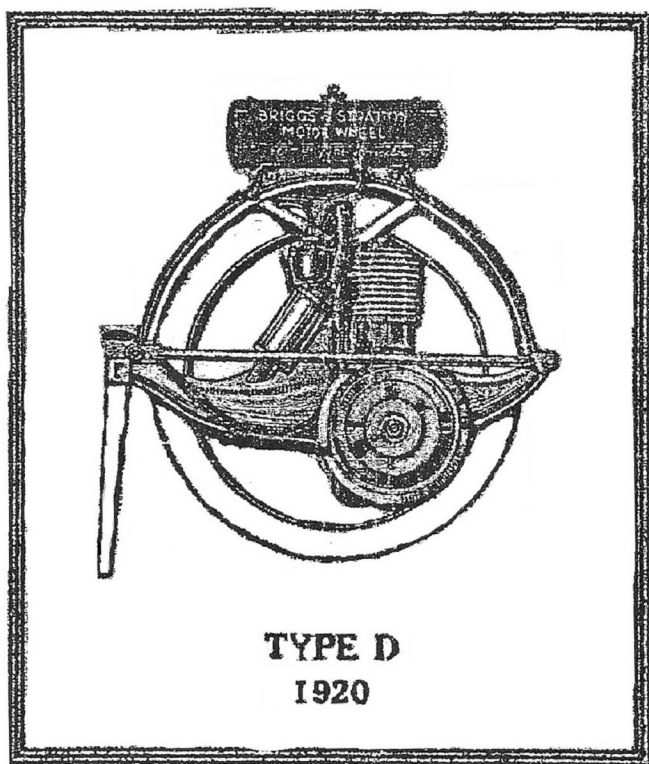

# Briggs & Stratton

## MOTOR WHEEL



TYPE D  
1920

MOTOR WHEEL DIVISION  
**BRIGGS & STRATTON COMPANY**  
MILWAUKEE WISCONSIN

# HOW to ORDER PARTS and AVOID INCONVENIENCES

This Parts Price Book is issued for the convenience of our customers when in need of repair parts. All parts are shown herein and individually numbered. Corresponding numbers with names of parts and assemblies, with full description are given on other pages. We use assembly numbers where sub-assemblies are required, thereby avoiding the necessity of the customer giving numbers of each individual piece.

INSTRUCTIONS GIVEN BELOW MUST BE CAREFULLY OBSERVED ON EACH ORDER. This, we assure you, will be to our mutual advantage, thus eliminating unnecessary correspondence.

## HOW TO ORDER

Write plainly and legibly when ordering parts. DO NOT WRITE ON ANY OTHER SUBJECT. Use the utmost care when selecting parts from parts book, by comparing parts with illustrations. Read description carefully.

PARTS ORDERS SHOULD BE PLACED WITH OUR NEAREST RECOGNIZED DEALER OR DISTRIBUTOR. Give part number and description of items wanted, and sub-assembly numbers and description when assemblies are required. Do not depend upon numbers cast on parts as being correct.

## GIVE SERIAL NUMBER

ALWAYS GIVE MOTOR NUMBER AND FLYER NUMBER WHEN ORDERING PARTS. The serial number of the Motor is stamped on the crank case, directly forward of the fly wheel. The serial number of the Flyer is placed on a plate nailed to cross beam in front of seats.

## RIGHT OR LEFT

"RIGHT OR LEFT" refer to opposite sides and are taken from the position of the driver behind steering wheel facing forward.

## SHIPPING INSTRUCTIONS

State, when ordering, whether shipment is desired to come forward by express, freight or parcel post.

## REMITTANCE

Remittance in full must accompany every order, unless customer has a deposit sufficient to cover value of parts ordered.

Remit in full by post office or express money order, or United States stamps. Stamps will be accepted for parts orders less than One Dollar (\$1.00) only. Always include with remittance sufficient amount to cover parcel post on mailable parts orders. Prices quoted in this parts book do not include the 5% Federal Tax, which must be added to shipments of this nature, when shipments are made to any place in the United States. Excess postage will be refunded. Mailable parts are forwarded at owner's risk. If material is to be forwarded by insured parcel post, mention so in your order and accompany order with an additional fee of ten cents (10c) to cover insurance. Remittance with order eliminates delay in shipment, and avoids annoyances of C. O. D. and return collection charges.

## PRICES

Prices quoted herein are subject to change without notice. Prices on tanks, wheels, axles, mudguards and steering gears include enameling. ALL PARTS ARE SOLD F. O. B. FACTORY.

## INSTRUCTIONS ON RETURNING PARTS

TAG EACH PART WITH MOTOR NUMBER FROM WHICH IT WAS TAKEN. PLACE NAME AND ADDRESS PLAINLY ON TAG. AT THE SAME TIME ADVISE US BY LETTER, EXPLAINING FULLY WHAT PARTS ARE BEING FORWARDED AND THE OBJECT FOR RETURNING. TRANSPORTATION CHARGES MUST BE PREPAID ON ALL SHIPMENTS TO THE FACTORY, OTHERWISE THEY WILL NOT BE ACCEPTED.

PRICES EFFECTIVE APRIL 1st, 1920.

PRICES SUBJECT TO CHANGE WITHOUT NOTICE.

---

# BRIGGS & STRATTON COMPANY

MOTOR WHEEL DIVISION      MILWAUKEE, WISCONSIN

| Part No.                   | DESCRIPTION   | Price<br>Each |
|----------------------------|---|---------------|
| <b>CRANK CASE DIVISION</b> |   |               |
| 13A-A                      | Muffler Assem.  | \$2.00        |
| 13A-B                      | Gear Case Cover Assem., consisting of 13A-21, 22, 23 and 3/32 x<br>1/8 Rivet. | 1.80          |
| 13A-D                      | Connecting Rod Assem., consisting of 13A-2, 27, 28, 31, 32, and 34,           | 3.50          |
| 13A-E                      | Breather Tube Assem.  | .32           |
| 13A-F                      | Crank Case Assem., consisting of 13A-E, 3, 18, 25, 26.                        | 19.25         |
| 13A-J                      | Pump Plunger Assem.   | .30           |
| 13A-L                      | Cam Follower and Guide Assem., consisting of 13A-30, 49, 50.                  | 2.75          |
| 13A-M                      | Oil Pan Assem., consisting of Oil Pan, Pump Body and Bull's Eye<br>Housing.   | 2.90          |
| 13A-1                      | Oil Pan Gasket.   | .12           |
| 13A-2                      | Lockwasher for Conn. Rod Screw  | .01           |
| 13A-3                      | Cam Shaft Bushing   | .90           |
| 13A-4                      | Pivot Pin   | 1.20          |
| 13A-5                      | Drain Plug Gasket.  | .05           |
| 13A-6                      | Drain Plug.   | .15           |
| 13A-9                      | Cylinder Gasket.  | .10           |
| 13A-10                     | Magneto Gasket.   | .12           |
| 13A-11                     | Fly Wheel Nut.  | .21           |
| 13A-13                     | Dip Trough  | .25           |
| 13A-15                     | Thrust Washer.  | .50           |
| 13A-16                     | Bearing Cover.  | .05           |
| 13A-19                     | Crank Shaft.  | 8.15          |
| 13A-20                     | Cam Shaft and Gear.   | 9.00          |
| 13A-21                     | Gear Cover } see 13A-B for Assem.   |               |
| 13A-22                     | Packing Retainer } Always furnished assembled.                                |               |
| 13A-23                     | Packing Ring  | .25           |
| 13A-24                     | Gear Cover Gasket.  | .18           |
| 13A-25                     | Bushing.  | 1.10          |
| 13A-26                     | Bushing.  | 1.00          |
| 13A-27                     | Conn. Rod Screw.  | .05           |
| 13A-29                     | Cam.  | 2.60          |
| 13A-30                     | Cam Follower.   | 1.25          |
| 13A-31                     | Conn. Rod Bushing (Upper)   | .36           |
| 13A-32                     | Conn. Rod Bushing (Lower)   | 1.00          |
| 13A-33                     | Cam Screw.  | .15           |
| 13A-34                     | Conn. Rod Shim.   | .07           |
| 13A-38                     | Pump Ball.  | .02           |
| 13A-39                     | Pump Rod.   | .08           |
| 13A-40                     | Pump Spring.  | .07           |
| 13A-46                     | Exhaust Pipe Spring.  | .10           |
| 13A-47                     | Bull's Eye Washer (Cork).   | .05           |
| 13A-48                     | Cam Follower Guide Screw.   | .07           |
| 13A-49                     | Cam Follower Guide.   | 1.45          |
| 13A-50                     | Cork Bushing.   | .05           |
| 7A24                       | Valve Adjusting Screw   | .07           |
| 7A39                       | Lockwasher for 7F11.  | .01           |
| 7A42                       | Woodruff Key.   | .07           |
| 7A54                       | Pivot Pin Nut.  | .13           |
| 7A55                       | Lockwasher for 7A54.  | .01           |
| 7A61                       | Lockwasher for 13W-5, 7A62.   | .01           |
| 7A62                       | Cap Screw for fastening Cylinder to Crank Case.                               | .10           |
| 7A84                       | Bull's Eye Retainer Nut.  | .23           |
| 7A85                       | Bull's Eye Washer (Leather).  | .05           |
| 7A86                       | Bull's Eye.   | .05           |
| 7A109                      | Adjusting Screw Locknut.  | .07           |
| 7A110                      | Filler Plug.  | .23           |
| 7A116                      | Guide Gasket.   | .04           |
| 7A123                      | Stand Channel Spring Screw.   | .11           |
| 7A145                      | Wrench.   | .19           |
| 7A146                      | Wrench.   | .20           |

Read instructions "How to Order." Always give MOTOR NUMBER when ordering parts.  
Give part number and full description on order.

| Part No.                 | DESCRIPTION  | Price Each |
|--------------------------|--|------------|
| <b>CYLINDER DIVISION</b> |  |            |
| 13B-F                    | Fan Assem., Complete.....                              | 4.50       |
| 13B-M                    | Fan Bracket with Shaft.....                            | .80        |
| 7B-C                     | Spark Plug with Gasket.....                            | 1.25       |
| 7B-R                     | Inlet Valve Assem., with 7B17.....                     | 2.00       |
| 7B-T                     | Elbow Clamp Set Screw Sub-Assem.....                   | .60        |
| 13B-1                    | Piston.....  | 2.50       |
| 13B-2                    | Piston Ring.....                                       | .36        |
| 13B-3                    | Cylinder.....  | 10.60      |
| 13B-5                    | Piston Pin.....  | .50        |
| 13B-6                    | Piston Pin Lock.....                                   | .02        |
| 13B-7                    | Intake Elbow.....                                      | 1.23       |
| 13B-8                    | Fan Bushing.....                                       | .30        |
| 13B-9                    | Fan Pulley.....  | .50        |
| 13B-12                   | Fan.....   | .75        |
| 13B-13                   | Cylinder Plug.....                                     | .30        |
| 13B-14                   | Cap Screw.....   | .05        |
| 13B-15                   | Escutcheon Pin.....                                    | .01        |
| 13B-16                   | Cotter Pin for Fan.....                                | .01        |
| 13B-17                   | Fan Belt.....  | .60        |
| 13B-18                   | Fan Shaft Washer.....                                  | .05        |
| 13B-19                   | Fan Drive Pulley.....                                  | 1.00       |
| 7B13                     | Exhaust Spring.....                                    | .06        |
| 7B14                     | Exhaust Spring Support.....                            | .09        |
| 7B15                     | Exhaust Spring Collar.....                             | .18        |
| 7B16                     | Exhaust Valve Pin.....                                 | .03        |
| 7B17                     | Gasket for 7B-R.....                                   | .03        |
| 7B24                     | Gasket for 7A110, 7B-C, 7B55.....                      | .03        |
| 7B25                     | Cap Screw for fastening Carburetor to Cylinder.....    | .04        |
| 7B30                     | Carburetor Gasket.....                                 | .05        |
| 7B33                     | Lockwasher for 7B25, 36.....                           | .01        |
| 7B35                     | Screw for 13K-9, 7K84.....                             | .01        |
| 7B36                     | Cap Screw for Mudguard Brace and Crank Case Cover..... | .05        |
| 7B55                     | Cylinder Plug.....                                     | .26        |
| 7B57                     | Priming Cup used on 7F-J, 13B-7.....                   | .15        |
| 7B75                     | Elbow Clamp.....                                       | .82        |
| 7B77                     | Exhaust Valve.....                                     | .66        |
| 7B83                     | Intake Elbow Spacer.....                               | .05        |

|                            |   |       |
|----------------------------|---|-------|
| <b>CARBURETOR DIVISION</b> |   |       |
| 13C-A                      | Carb. Complete with Shield.....                             | 13.15 |
| 7C-F                       | Carb. Cover Sub-Assem., consisting of 7C32, 52, 53, 54..... | 1.75  |
| 7C-R                       | Carb. Piston Sub-Assem.....                                 | 1.20  |
| 13C-1                      | Carb. Body with 7C55.....                                   | 7.80  |
| 13C-3                      | Nozzle.....   | .45   |
| 13C-4                      | Nozzle Plug.....  | .20   |
| 13C-5                      | Nozzle Gasket.....  | .02   |
| 13C-6                      | Nozzle Spring.....  | .03   |
| 7C32                       | Carburetor Cover.....                                       | 1.55  |
| 7C33                       | Carb. Cover Screw.....                                      | .02   |
| 7C34                       | Strainer for 7C32.....                                      | .12   |
| 7C35                       | Strainer Cap for 7C32.....                                  | .47   |
| 7C36                       | Carburetor Float.....                                       | 1.00  |
| 7C37                       | Float Pin.....  | .20   |
| 7C38                       | Drain Plug.....   | .10   |
| 7C52                       | Flooder Pin.....  | .06   |
| 7C53                       | Flooder Pin Spring.....                                     | .02   |
| 7C54                       | Flooder Pin Cotter.....                                     | .01   |
| 7C55                       | Strainer for Carb. Flange.....                              | .10   |
| 7C57                       | Carb. Cover Gasket.....                                     | .04   |
| 7C62                       | Piston Spring.....  | .10   |
| 7C65                       | Carburetor Shield.....                                      | .18   |
| 7C125                      | Carburetor Cap.....   | .25   |

Read instructions "How to Order." Always give MOTOR NUMBER when ordering parts.  
Give part number and full description on order.

| Part No.                         | DESCRIPTION  | Price Each |
|----------------------------------|--|------------|
| <b>FRAME ATTACHMENT DIVISION</b> |  |            |
| 7F-I                             | Vertical Frame Stay Sub-Assem.   | 2.35       |
| 7F-J                             | Frame Attachment Complete.   | 5.93       |
| 7F-K                             | Horizontal Frame Stay Sub-Assem., consisting of 7F-2, 17, 43, 44, 45.  | 3.60       |
| 7F-L                             | Stand Sub-Assem., consisting of 7A123, 7F26, 27, 32, 47, 48, 49, 7T16. | 3.00       |
| 7F-3                             | Buffer Spring  | .04        |
| 7F-4                             | Castellated Nut  | .16        |
| 7F-5                             | Cotter Pin   | .01        |
| 7F10                             | Upper Clamp  | .50        |
| 7F11                             | Bolt for 7F10  | .09        |
| 7F12                             | Nut for 7F11   | .05        |
| 7F17                             | Forward Clamp  | .50        |
| 7F18                             | Bolt for 7F10, 17  | .11        |
| 7F20                             | Nut for 7F18   | .05        |
| 7F22                             | Lockwasher for 7F18, 33, 13A-48  | .01        |
| 7F26                             | Swivel Pin   | .10        |
| 7F27                             | Swivel Pin Collar  | .03        |
| 7F32                             | Stand Clip   | .08        |
| 7F33                             | Bolt for 7F17  | .10        |
| 7F34                             | Nut for 7F33   | .05        |
| 7F35                             | Lower Forward Clamp for Chainless Bicycle                              | .50        |
| 7F36                             | Upper Clamp for Cushion Frame Bicycle                                  | .78        |
| 7F45                             | Frame Bracket  | 1.65       |
| 7F47                             | Stand Spring   | .10        |
| 7F48                             | Swivel Nut   | 1.03       |
| 7F49                             | Stand Channel (See 7F-L, always furnished assembled)                   |            |

#### FLYER DIVISION

|      |   |       |
|------|---|-------|
| 7J-B | Front Axle Complete with Cones and Nuts, less Bearings and Hubs,                          | 13.10 |
| 7J-C | Rear Axle Complete with Cones and Nuts, less Bearings and Hubs,                           | 9.42  |
| 7J-D | Steering Gear Complete.   | 7.64  |
| 7J-F | R. H. Front Mudguard Assem., consisting of 7J57, 58, 60, 65, 127, 128, 131, 7K20, 22, 24. | 3.00  |
| 7J-F | L. H. Front Mudguard Assem., consisting of 7J57, 58, 59, 65, 127, 128, 131, 7K20, 22, 24. | 3.00  |
| 7J-G | R. H. Rear Mudguard Assem., consisting of 7J61, 62, 63, 125, 127, 128, 145.               | 2.75  |
| 7J-G | L. H. Rear Mudguard Assem., consisting of 7J61, 62, 64, 126, 127, 128, 145.               | 2.75  |
| 7J-I | Brake Rod Sub-Assem.  | 1.98  |
| 7J-J | Steering Wheel Sub-Assem., consisting of 7J-8, 79, 80.                                    | 4.40  |
| 7J-L | Cranking Knob Assem., consisting of 7A39, 7F12, 7J66, 107, 108, 109                       | 1.05  |
| 7J-O | Flyer Wheel Assem., consisting of 7J49, 50, 51, 52, 53, 54.                               | 5.00  |
| 7J-P | R. H. Seat Sub-Assem.   | 7.17  |
| 7J-P | L. H. Seat Sub-Assem.   | 7.17  |
| 7J-Q | R. H. Front Mudguard Brace Assem., consisting of 7J58, 60, 127, 128, 131.                 | 1.80  |
| 7J-Q | L. H. Front Mudguard Brace Assem., consisting of 7J58, 59, 127, 128, 131.                 | 1.80  |
| 7J-R | R. H. Rear Mudguard Brace Assem., consisting of 7J63, 125, 127, 128.                      | 1.05  |
| 7J-R | L. H. Rear Mudguard Brace Assem., consisting of 7J64, 126, 127, 128.                      | 1.05  |
| 7J-S | Valve Inside  | .08   |
| 7J-T | Valve Complete  | .25   |
| 7J-U | R. H. Front Spindle with 7J19.  | 3.50  |
| 7J-U | L. H. Front Spindle with 7J19.  | 3.25  |
| 7J-V | R. H. Rear Spindle with 7J19, 29.   | 2.25  |
| 7J-V | L. H. Rear Spindle with 7J19, 29.   | 2.25  |

Read instructions "How to Order." Always give MOTOR NUMBER when ordering parts.  
Give part number and full description on order.

## FLYER DIVISION—Con't.

|      |  |      |
|------|--|------|
| 7J-W | Hand Lever Rod Assem., consisting of 7J42, 43, 44, 84, 89, 94, 7T17; | 1.50 |
| 7J-X | Hand Lever Assem., consisting of 7J31, 39, 41                        | 1.75 |
| 7J-1 | Steering Post Lever  | .78  |
| 7J-2 | Steering Post Bracket  | .80  |
| 7J-7 | Motor Wheel Attaching Bracket  | 1.60 |
| 7J-8 | Steering Wheel Spider  | 2.00 |
| 7J-9 | Brake Pedal  | 1.42 |
| 7J12 | Pivot Pin  | 1.00 |
| 7J13 | Front Axle Channel   | 2.38 |
| 7J15 | Drag Link  | .60  |
| 7J16 | Steering Gear Spring   | .25  |
| 7J17 | Steering Spring Clip   | .15  |
| 7J19 | Stationary Cone  | .60  |
| 7J20 | L. H. Adj. Cone, R. H. Thread  | .62  |
| 7J22 | Rear Axle Channel  | 2.54 |
| 7J25 | Steering Post  | 1.52 |
| 7J27 | Steering Post Collar   | .25  |
| 7J28 | Brake Beam Support   | .60  |
| 7J29 | Bearing Dust Washer  | .08  |
| 7J30 | L. H. Adj. Locknut, R. H. Thread                                     | .08  |
| 7J31 | Ferrule  | .14  |
| 7J32 | Steering Spider Pin  | .05  |
| 7J33 | Floor Brace  | .48  |
| 7J34 | Release Spring   | .05  |
| 7J38 | Washer for 7J92, 139, 149  | .01  |
| 7J39 | Hand Lever   | 1.45 |
| 7J40 | Hand Lever Swivel  | .60  |
| 7J41 | Hand Lever Knob with 7J31  | .30  |
| 7J42 | Hand Lever Rod   | .80  |
| 7J43 | R. H. Motor Lifting Clamp  | .43  |
| 7J44 | L. H. Motor Lifting Clamp  | .43  |
| 7J47 | Pin Spacer for 7J119   | .20  |
| 7J48 | Rear Axle Channel Spacer   | .27  |
| 7J49 | Hub  | 3.00 |
| 7J50 | Rim  | 1.10 |
| 7J51 | Ball   | .02  |
| 7J52 | Ball Retainer  | .08  |
| 7J53 | Spoke  | .04  |
| 7J54 | Nipple   | .02  |
| 7J55 | U. S. Casing, 20" x 1 $\frac{5}{8}$ "                                | 3.25 |
| 7J56 | U. S. Inner Tube, 20" x 1 $\frac{5}{8}$ "                            | 1.25 |
| 7J58 | Front Mudguard Horizontal Brace (See 7J-Q for Assem.)                | .46  |
| 7J59 | L. H. Front Mudguard Vertical Brace (See 7J-Q for Assem.)            | .60  |
| 7J60 | R. H. Front Mudguard Vertical Brace (See 7J-Q for Assem.)            | .60  |
| 7J62 | Rear Mudguard Bracket  | .53  |
| 7J63 | R. H. Rear Mudguard Brace (See 7J-R for Assembly)                    | .54  |
| 7J64 | L. H. Rear Mudguard Brace (See 7J-R for Assembly)                    | .54  |
| 7J65 | Splasher   | .41  |
| 7J66 | Cranking Knob  | .30  |
| 7J67 | No. 1 Floor Slat   | 1.25 |
| 7J68 | No. 2 Floor Slat   | 1.25 |
| 7J69 | No. 3 Floor Slat   | 1.25 |
| 7J70 | No. 4 Floor Slat   | 1.25 |
| 7J71 | No. 5 Floor Slat   | 1.25 |
| 7J72 | No. 6 Floor Slat   | 1.25 |
| 7J73 | Foot Rest  | 1.00 |
| 7J74 | Seat Cross Beam (Front)  | .90  |
| 7J75 | Brake Beam   | .90  |
| 7J79 | Steering Wheel Rim   | 2.00 |
| 7J80 | Steering Rim Screw   | .03  |
| 7J81 | Button Head Stove Bolt   | .03  |
| 7J82 | Button Head Stove Bolt   | .02  |

Read instructions "How to Order." Always give MOTOR NUMBER when ordering parts.  
Give part number and full description on order.

| Part No.                     | DESCRIPTION   | Price<br>Each |
|------------------------------|---|---------------|
| <b>FLYER DIVISION—Con't.</b> |   |               |
| 7J83                         | Button Head Stove Bolt.....                           | .01           |
| 7J84                         | Button Head Stove Bolt.....                           | .01           |
| 7J86                         | Button Head Stove Bolt.....                           | .01           |
| 7J87                         | Button Head Machine Screw.....                        | .01           |
| 7J88                         | Nut.....  | .01           |
| 7J89                         | Nut.....  | .01           |
| 7J92                         | Carriage Bolt (Seat to Seat Cross Beam and Slat)..... | .08           |
| 7J93                         | Hexagon Nut.....                                      | .03           |
| 7J94                         | Cotter Pin for 7J12, 15, 40, 42, 130, 135, 136.....   | .01           |
| 7J95                         | Button Head Wood Screw.....                           | .01           |
| 7J96                         | Washer for 7J81, 82.....                              | .01           |
| 7J99                         | Rear Axle Brace.....                                  | .38           |
| 7J100                        | Brake Pedal Pin for 7J-9.....                         | .07           |
| 7J103                        | R. H. Adj. Cone, L. H. Thread.....                    | .62           |
| 7J104                        | R. H. Adj. Locknut, L. H. Thread.....                 | .11           |
| 7J106                        | Hexagon Nut for 7J42.....                             | .03           |
| 7J107                        | Cranking Knob Outer Spacer.....                       | .11           |
| 7J108                        | Cranking Knob Inner Spacer.....                       | .39           |
| 7J109                        | Cranking Knob Stud.....                               | .65           |
| 7J116                        | Washer for 7J86, 124.....                             | .01           |
| 7J119                        | Pin for 7J-9, 39.....                                 | .26           |
| 7J120                        | Pin Clip for 7J119.....                               | .16           |
| 7J121                        | R. H. Seat Brace.....                                 | 1.61          |
| 7J122                        | L. H. Seat Brace.....                                 | 1.61          |
| 7J123                        | Angle Brace.....                                      | .21           |
| 7J124                        | Button Head Screw.....                                | .02           |
| 7J125                        | R. H. Rear Mudguard Brace Support.....                | .18           |
| 7J126                        | L. H. Rear Mudguard Brace Support.....                | .18           |
| 7J127                        | Mudguard Brace Tip.....                               | .16           |
| 7J128                        | Bearing Dust Washer.....                              | .15           |
| 7J129                        | Hand Lever Quadrant.....                              | .78           |
| 7J130                        | Steering Post Brace.....                              | .84           |
| 7J131                        | Mudguard Brace Connector.....                         | .39           |
| 7J132                        | Screw.....  | .02           |
| 7J133                        | Button Head Stove Bolt.....                           | .01           |
| 7J134                        | Turnbuckle.....                                       | .75           |
| 7J135                        | Cross Connection, R. H. Thread.....                   | .60           |
| 7J136                        | Cross Connection, L. H. Thread.....                   | .60           |
| 7J137                        | Locknut, R. H. Thread.....                            | .05           |
| 7J138                        | Locknut, L. H. Thread.....                            | .05           |
| 7J139                        | Carriage Bolt (Seat to Front Cross Beam).....         | .05           |
| 7J140                        | Control Clamp Split Bushing (Two Halves).....         | .65           |
| 7J141                        | Wood Screw.....                                       | .01           |
| 7J144                        | Seat Transfer.....                                    | .15           |
| 7J145                        | Brake Lining.....                                     | .60           |
| 7J147                        | Seat Post (Rear).....                                 | .48           |
| 7J148                        | Seat Post (Front).....                                | .60           |
| 7J149                        | Carriage Bolt (Seat to Rear Cross Beam and Slat)..... | .05           |
| 7J150                        | Seat Cross Beam (Rear).....                           | .80           |

### CONTROL DIVISION

|       |   |      |
|-------|---|------|
| 13K-A | Compression Relief Lever Sub-Assem., consisting of 13K-7, 11, 7K33, 37, 113, 117, 119, 120..... | 2.80 |
| 13K-B | Valve Lifter Sub-Assem., consisting of 13K-1, 7K23, 33, 111, 118..                              | 1.50 |
| 13K-C | Carburetor Control Assem., consisting of 13K-E, 7K-O, 10, 45....                                | 6.10 |
| 13K-D | Compression Relief Lever Assem., consisting of 13K-A, B, 2, 7K10, 7K45.....                     | 5.00 |
| 13K-E | Control Lever Sub-Assem., consisting of 13K-3, 5, 6, 10, 12, 7K23, 33, 41, 68, 77, 78.....      | 4.30 |
| 7K-O  | Carburetor Connection Sub-Assem., consisting of 7K33, 47, 86...                                 | 1.05 |
| 13K-1 | Valve Lifter Connection with 7K111.....   | 1.21 |

*Read instructions "How to Order." Always give MOTOR NUMBER when ordering parts.  
Give part number and full description on order.*

| Part No.                       | DESCRIPTION                      | Price<br>Each |
|--------------------------------|----------------------------------|---------------|
| <b>CONTROL DIVISION—Con't.</b> |                                  |               |
| 13K-2                          | Valve Lifter Spring              | .10           |
| 13K-3                          | Control Lever Plain Washer       | .08           |
| 13K-4                          | Control Lever Bushing            | .10           |
| 13K-5                          | Control Lever                    | .87           |
| 13K-6                          | Control Lever Base               | 1.00          |
| 13K-7                          | Lever Bracket                    | .70           |
| 13K-9                          | Casing Clamp                     | .07           |
| 13K-10                         | Control Lever Cap Screw          | .10           |
| 13K-11                         | Bracket Clamp                    | .30           |
| 13K-12                         | Base Support Clamp               | .30           |
| 7K10                           | Control Wire Casing              | .55           |
| 7K10-1                         | Control Wire Casing (9 ft. long) | .70           |
| 7K20                           | Short Clip Screw used on 7C65    | .01           |
| 7K22                           | Nut for 7K20                     | .01           |
| 7K23                           | Cotter Pin for 7K41, 118         | .01           |
| 7K24                           | Lockwasher for 7K20              | .01           |
| 7K33                           | Set Screw for 7K41, 86, 117      | .05           |
| 7K41                           | Swivel Pin                       | .27           |
| 7K45                           | Control Wire                     | .15           |
| 7K45-1                         | Control Wire (9 ft. 6 in. long)  | .20           |
| 7K47                           | Cotter Pin for 7K86, 7FX22, 23   | .01           |
| 7K68                           | Spring Washer                    | .08           |
| 7K77                           | Casing Clamp Screw for 13K-6, 7  | .01           |
| 7K78                           | Clamp Screw                      | .01           |
| 7K84                           | Control Casing Clip              | .10           |
| 7K86                           | Carb. Connection                 | .98           |
| 7K88                           | Frame Clip                       | .07           |
| 7K91                           | Vertical Stay Clip               | .08           |
| 7K111                          | Valve Lifter with 13K-1          | 1.21          |
| 7K113                          | Relief Lever                     | .45           |
| 7K117                          | Swivel for 7K113                 | .20           |
| 7K118                          | Valve Lifter Pin                 | .16           |
| 7K119                          | Relief Lever Screw               | .19           |
| 7K120                          | Clamp Screw                      | .01           |

### MAGNETO DIVISION

|        |   |       |
|--------|---|-------|
| 13M-B  | Armature Assem. (See 13M-K for Assem.)              | 9.80  |
| 13M-C  | Fly Wheel Assem. Complete                           | 11.00 |
| 13M-D  | Breaker Arm with Contact Point and Fibre Bushing    | 1.75  |
| 13M-E  | Contact Bracket with Point                          | 1.00  |
| 13M-F  | Ignition Cable with Terminal                        | .45   |
| 13M-G  | Condenser Assem. Complete                           | 2.50  |
| 13M-K  | Crank Case Cover Assem., including 13M-B and 13M-33 | 15.80 |
| 13M-2  | Armature Core Screw                                 | .05   |
| 13M-8  | Ignition Cable Bushing                              | .15   |
| 13M-10 | Spring Stud   | .05   |
| 13M-12 | Bracket Bushing                                     | .06   |
| 13M-13 | Breaker Arm Spring                                  | .05   |
| 13M-14 | Drain Tube  | .10   |
| 13M-17 | Bracket Washer                                      | .05   |
| 13M-18 | Spring Washer                                       | .05   |
| 13M-19 | Breaker Arm Stud                                    | .08   |
| 13M-20 | Armature Core Dowel                                 | .08   |
| 13M-21 | Bracket Shim  | .05   |
| 13M-22 | Ignition Cable Clamp                                | .07   |
| 13M-33 | Coil Insulator                                      | .10   |
| 13M-36 | Filister Head Screw for 13M-E                       | .02   |
| 13M-47 | Screw for Condenser                                 | .03   |
| 13M-50 | Armature Lead Insulation                            | .05   |

*Read instructions "How to Order." Always give MOTOR NUMBER when ordering parts.  
Give part number and full description on order.*



| Part No.                           | DESCRIPTION   | Price Each |
|------------------------------------|---|------------|
| <b>TANK AND MUD GUARD DIVISION</b> |   |            |
| 13T-A                              | Gas. Pipe Sub-Assem.....  | .80        |
| 13T-C                              | Gas. Tank less Priming Gun.....                                     | 3.00       |
| 7T-C                               | Gas. Shut-Off Valve.....  | .69        |
| 7T-K                               | Priming Gun Sub-Assem.....  | 1.00       |
| 7T-O                               | Mudguard Sub-Assem.....   | 6.50       |
| 13T-1                              | M. W. Guard Rail.....   | 1.50       |
| 13T-2                              | 1/8 x 1/2 Rivet.....  | .01        |
| 13T-4                              | 1/8 x 3/8 Rivet.....  | .01        |
| 13T-5                              | Tank Transfer.....  | .15        |
| 7T14                               | Lockwasher for 7T19.....  | .01        |
| 7T16                               | Nut for 7A123.....  | .01        |
| 7T17                               | Lockwasher for 7K84, 13K-9, 13A-B, 13A-M, 13M-B, 13M-22, 13M47..... | .01        |
| 7T19                               | Nut for 7T34.....   | .06        |
| 7T34                               | Support Bracket.....  | .84        |
| 7T39                               | Tank Support Bracket.....   | .36        |
| 7T45                               | Gas. Tank Nut.....  | .06        |
| 7T46                               | Gas. Tank Pad.....  | .02        |
| 7T51                               | Washer for 7T-K.....  | .01        |
| 7T52                               | Lockwasher for 7T45.....  | .01        |
| 7T55                               | Front Mudguard Brace.....   | .10        |
| 7T56                               | Rear Mudguard Brace.....  | .10        |

#### TRACTION WHEEL DIVISION

|       |                                 |      |
|-------|---------------------------------|------|
| 13W-A | Traction Wheel.....             | 7.50 |
| 13W-5 | Traction Wheel Screw.....       | .10  |
| 7W-X  | Valve Inside.....               | .08  |
| 7W-Y  | Valve Complete.....             | .25  |
| 7W-8  | Screw for 13A-B, M, 13M-22..... | .03  |
| 7W10  | Casing, 20" x 2".....           | 5.00 |
| 7W11  | Tube, 20" x 2".....             | 1.25 |

#### RAILROAD SPEEDSTER DIVISION

|        |   |       |
|--------|---|-------|
| 7F-X   | R. R. Speedster Attachment Complete.....  | 15.00 |
| 7FX-Y  | Horizontal Stay Assem., including 7FX-4, 7FX-5A, 8, 9, 11, 19, MO981, 10X18, 10X27, 17X9..... | 12.55 |
| 7FX-5  | Lever.....  | 1.10  |
| 7FX-5A | Lifter Spoon.....   | 1.50  |
| 7FX-6  | Release Lever.....  | .64   |
| 7FX-7  | Pawl.....   | .70   |
| 7FX-8  | Clamp Collar.....   | .74   |
| 7FX-9  | Quadrant.....   | 1.65  |
| 7FX-10 | Tie Rod.....  | .79   |
| 7FX-11 | Support Bracket.....  | 2.50  |
| 7FX-17 | Release Rod.....  | .62   |
| 7FX-18 | Release Lever Spring.....   | .15   |
| 7FX-19 | Bearing Block.....  | .20   |
| 7FX-21 | End Clamp Bracket.....  | .55   |
| 7FX-22 | 1/4 x 1 Rivet for 7FX7.....   | .01   |
| 7FX-23 | 1/4 x 3/4 Rivet for 7FX6.....   | .01   |
| 7FX-24 | Lifting Flange.....   | 3.00  |
| MO981  | Bolt for 7FX-9, 21.....   | .10   |
| 10X18  | Nut for 17X10, 9.....   | .09   |
| 10X27  | Nut for MO981.....  | .09   |
| 17X-9  | Bolt for 7FX8.....  | .10   |
| 17X10  | Bolt for 7FX-5.....   | .10   |
|        | 3/16 x 1 1/8 Rivet for 7FX-19.....  | .01   |

Read instructions "How to Order." Always give MOTOR NUMBER when ordering parts.  
Give part number and full description on order



13A1



13A24



13A23

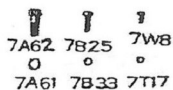

7B77



13B7



7BC



7BR



7A110



13A11



7A42

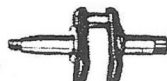

13A19



7B57



7B24



7B17



7B24



13B3



13A31



7A24

7A109



7B13



7BT



13A9



7B14



7B83



7B15



7B75



7B16



13A20



13AA



13B2



7B55



7B24



13A48

13A50



13A39

13A40

13A38

13AJ

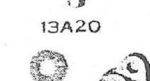

13A15



13A46



13B6



13B5



13B1

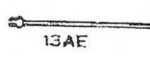

13AE



13A13



13A29

13A33

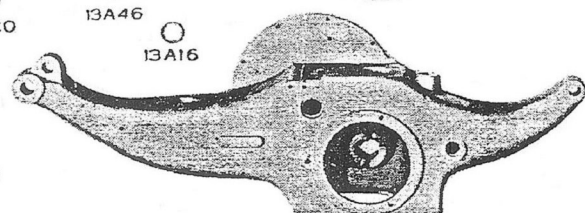

13AF

13A3

13A6

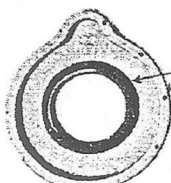

13A22

13A21

13A26



13AM

13A5

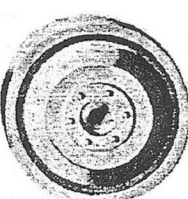

13MC



13AB

13A25

13A47

7A86

7A85

7A84

Read instructions "How to Order." Always give MOTOR NUMBER when ordering parts.

Give part number and description on order.

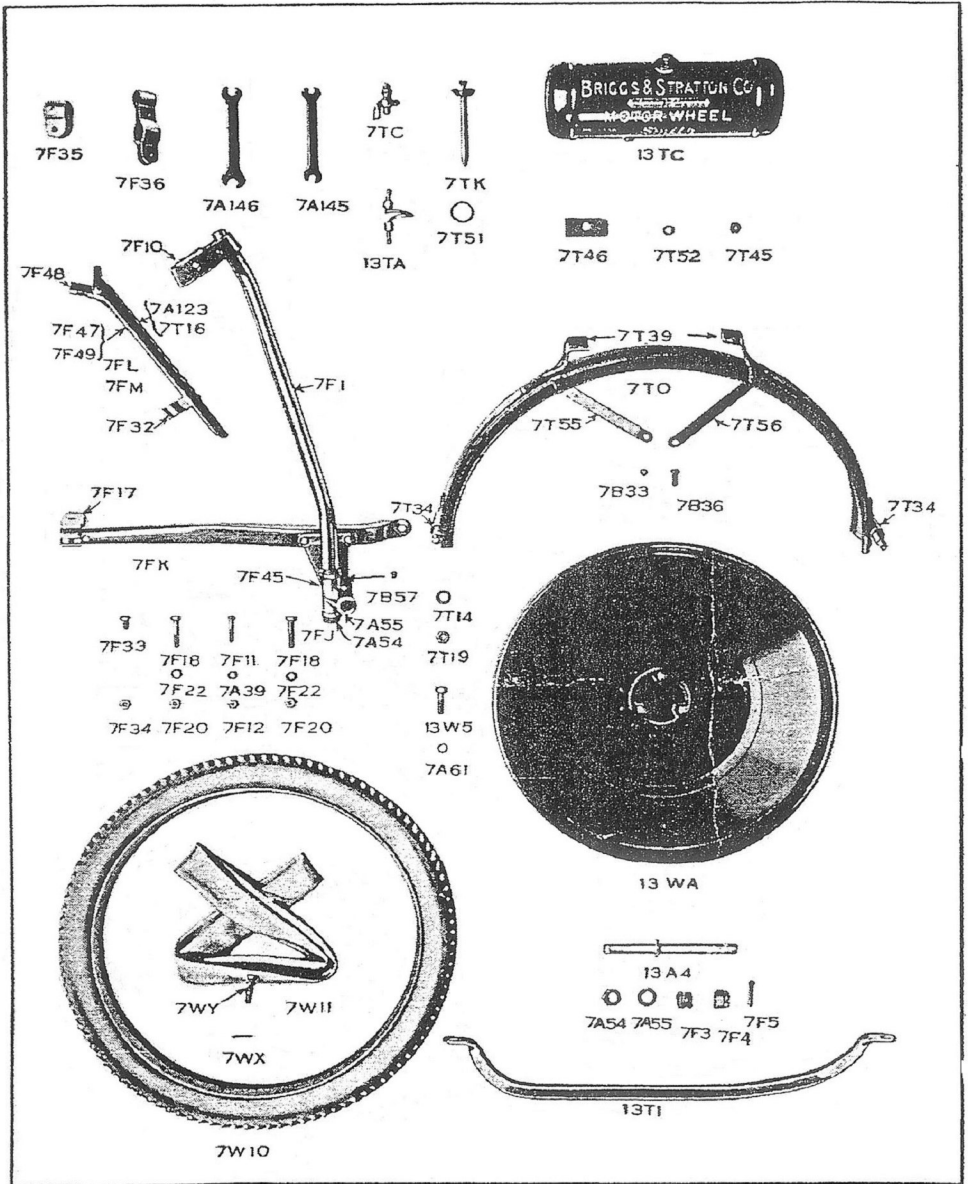

Read instructions "How to Order." Always give MOTOR NUMBER when ordering parts.

Give part number and full description on order.

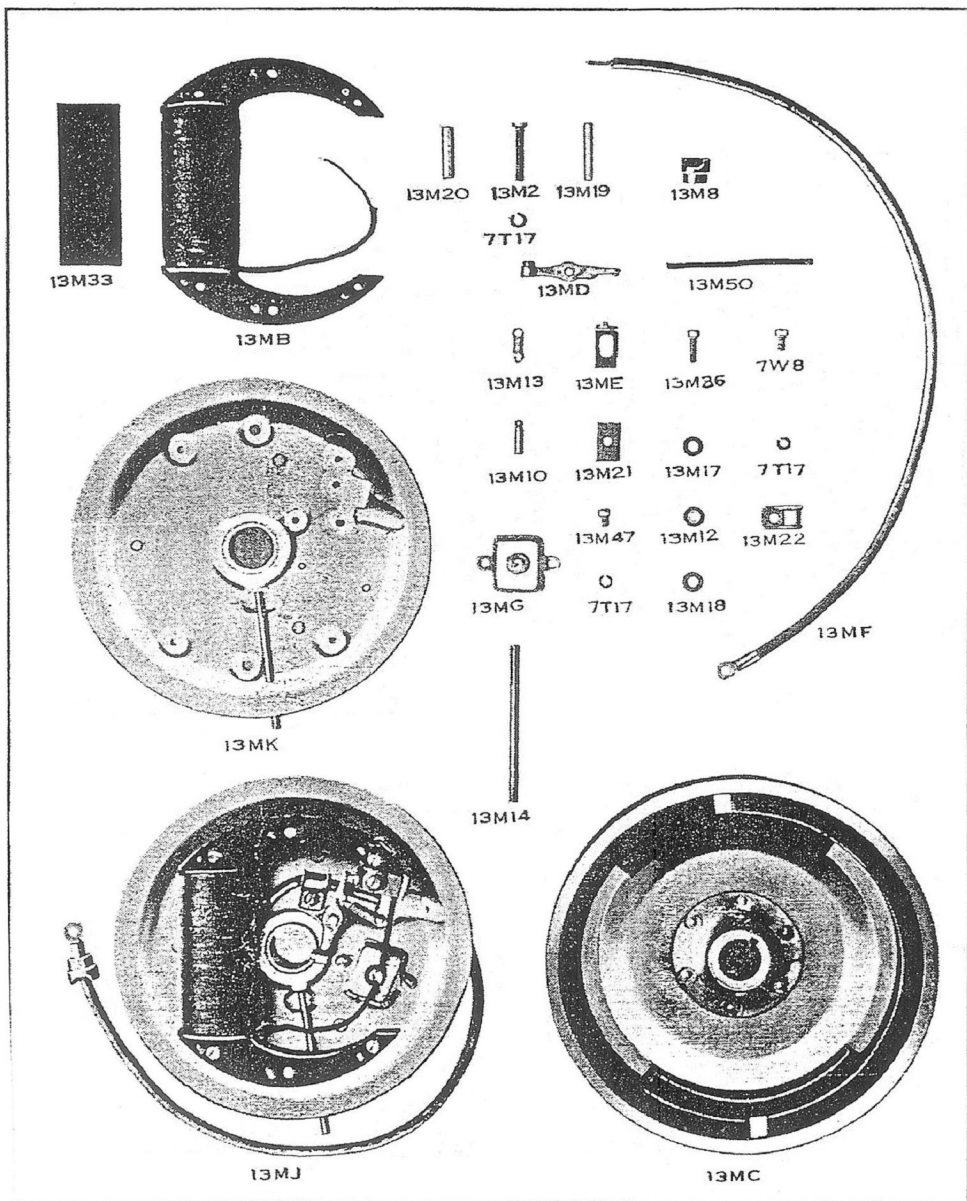

*Read instructions "How to Order." Always give MOTOR NUMBER  
 when ordering parts.*

*Give part number and full description on order.*

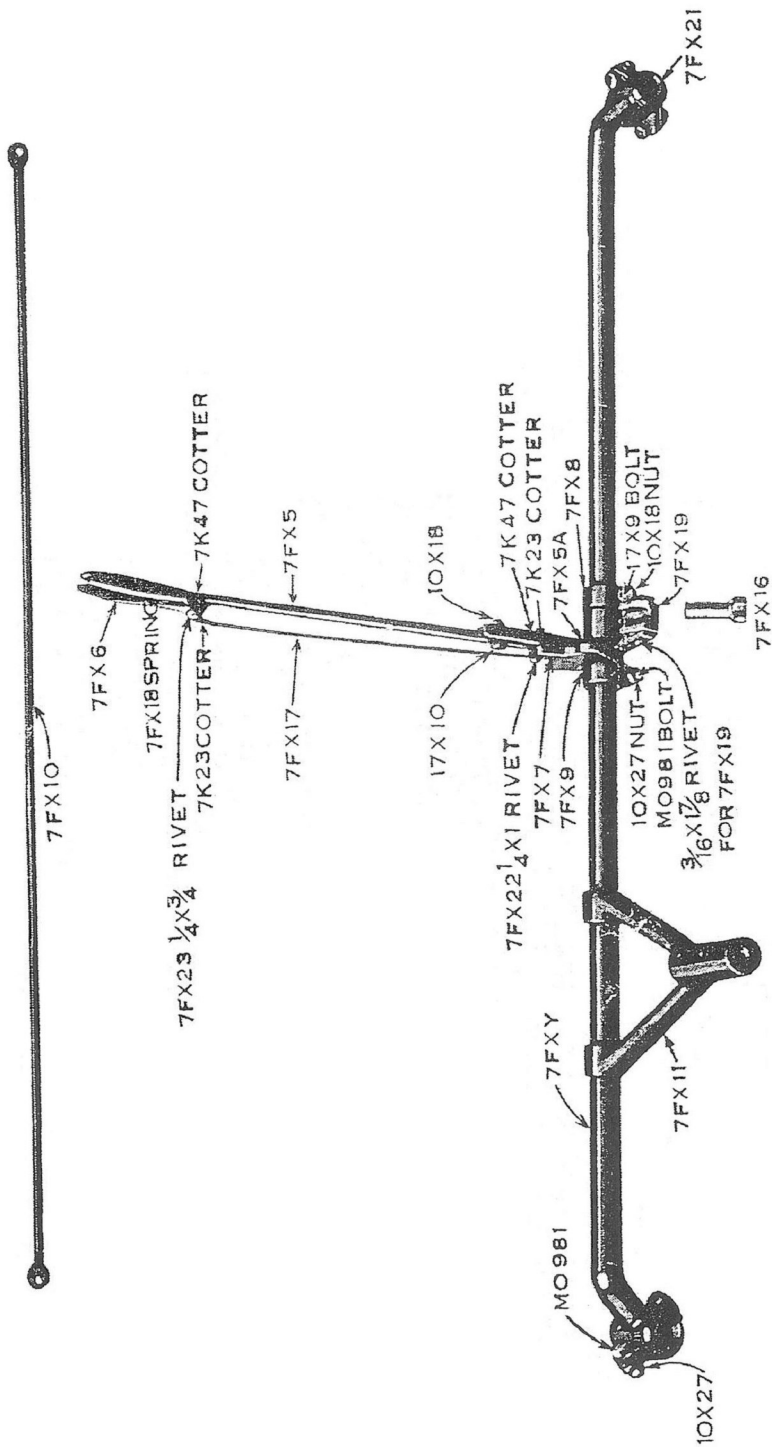

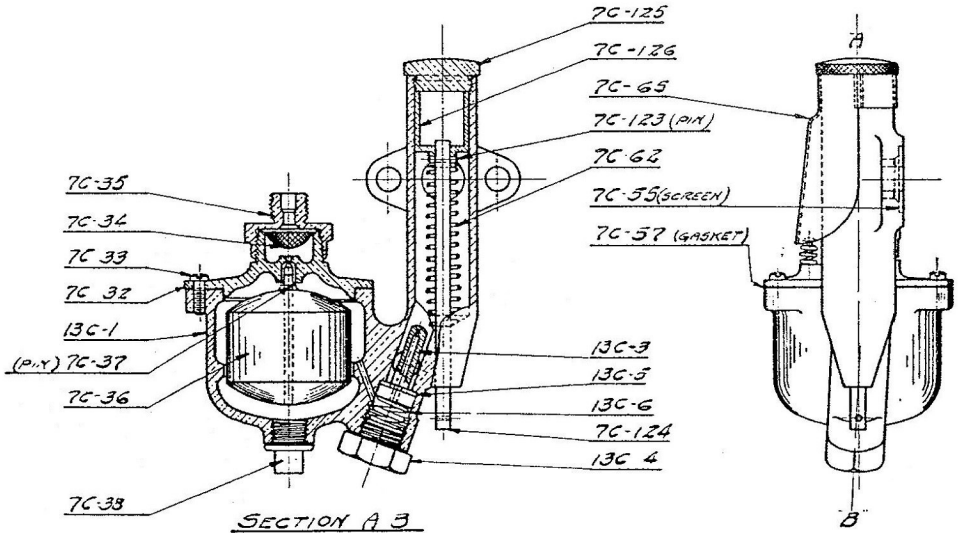
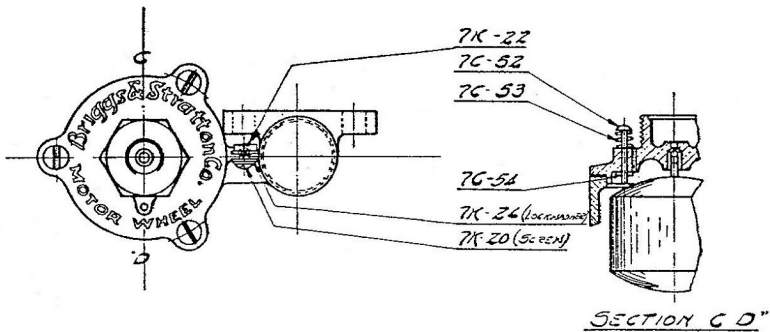

FOR MOTORWHEEL ASSEMBLY SEE 3000 Z7-H

Read instructions "How to Order." Always give MOTOR NUMBER  
when ordering parts.

Give part number and full description on order.

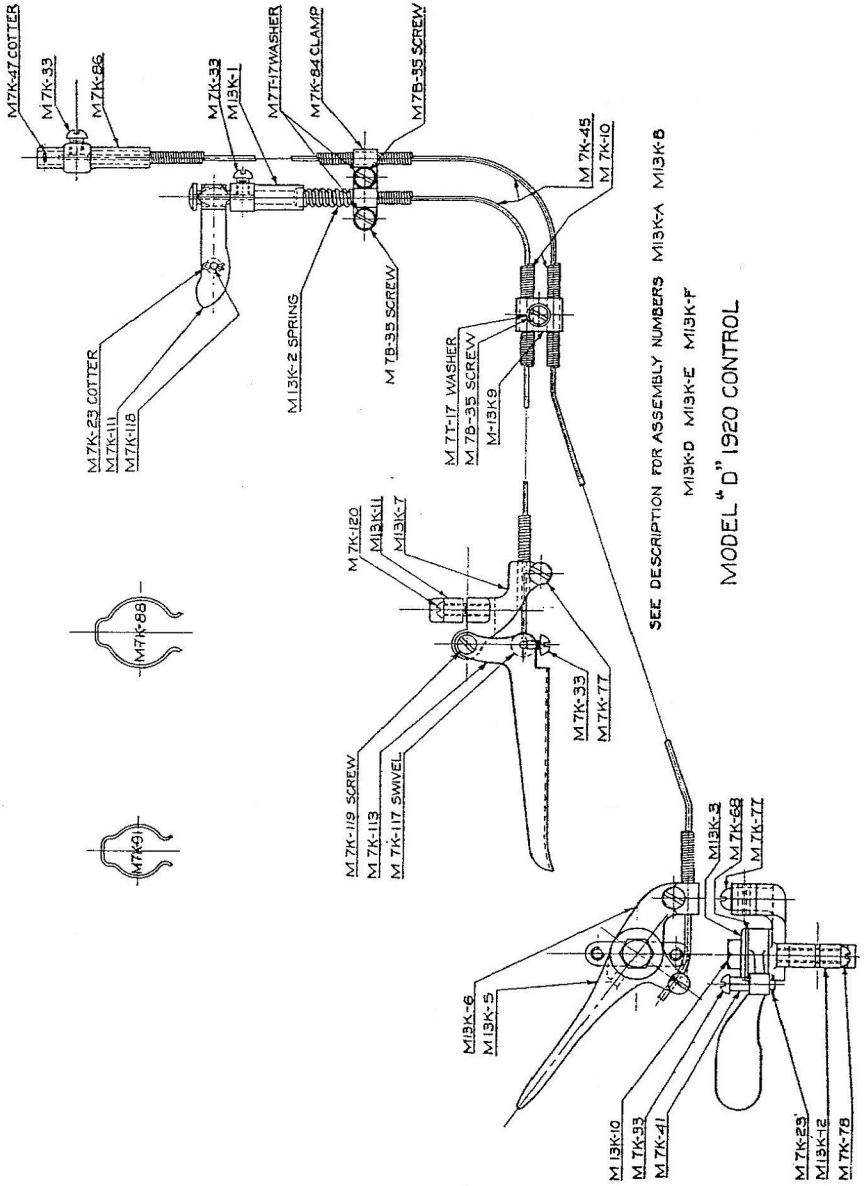

SEE DESCRIPTION FOR ASSEMBLY NUMBERS M13K-A M13K-B  
 M13K-D M13K-E M13K-F

MODEL "D" 1920 CONTROL

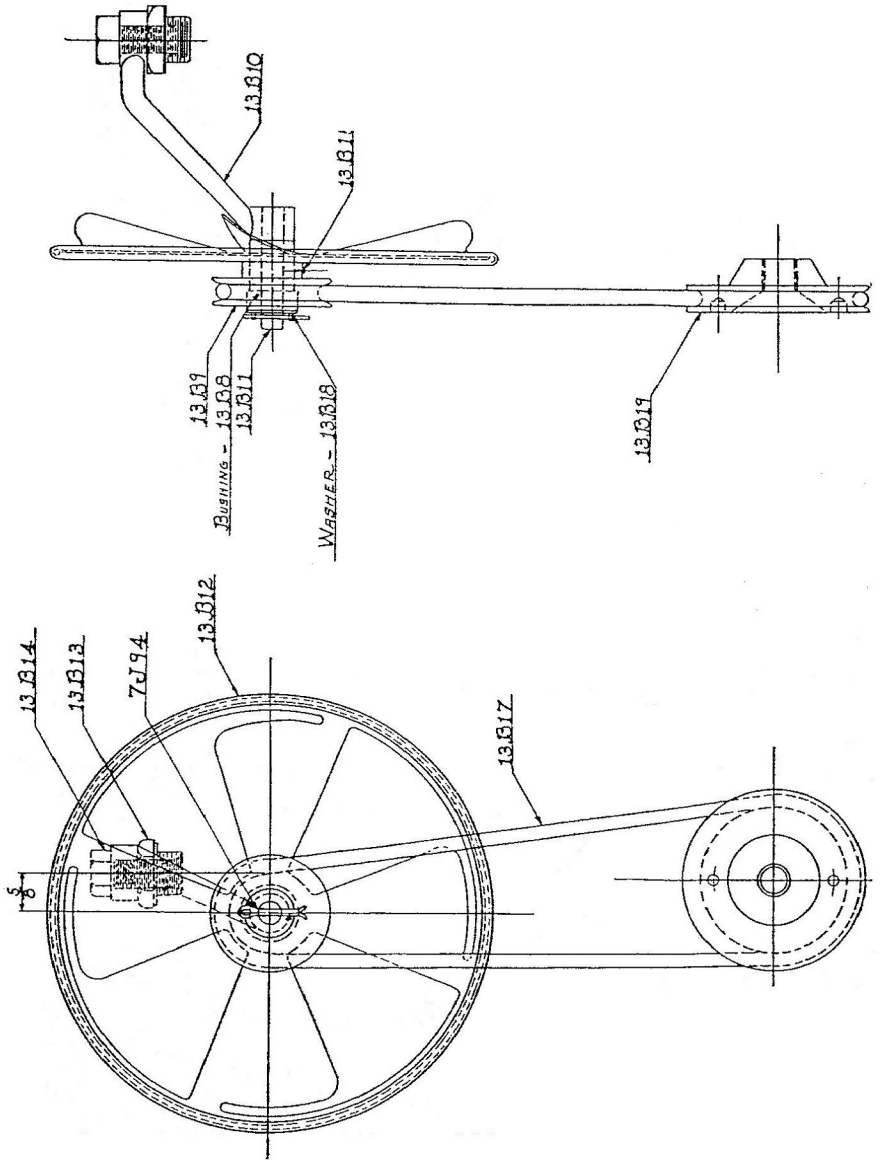



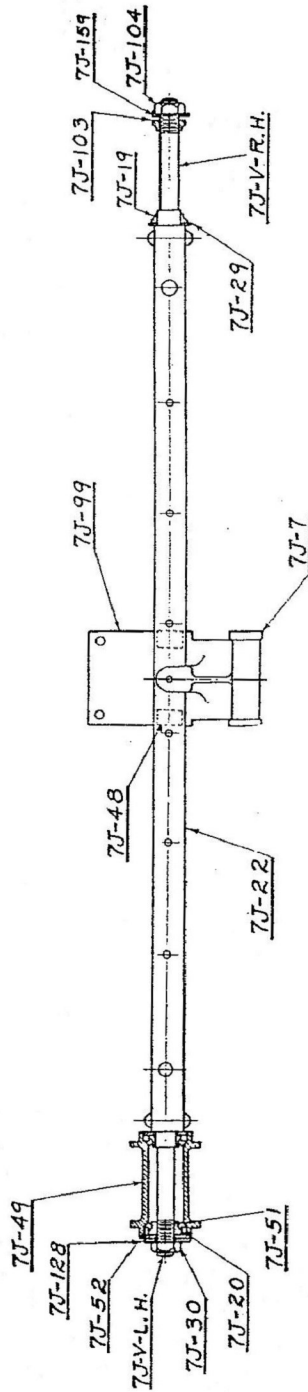
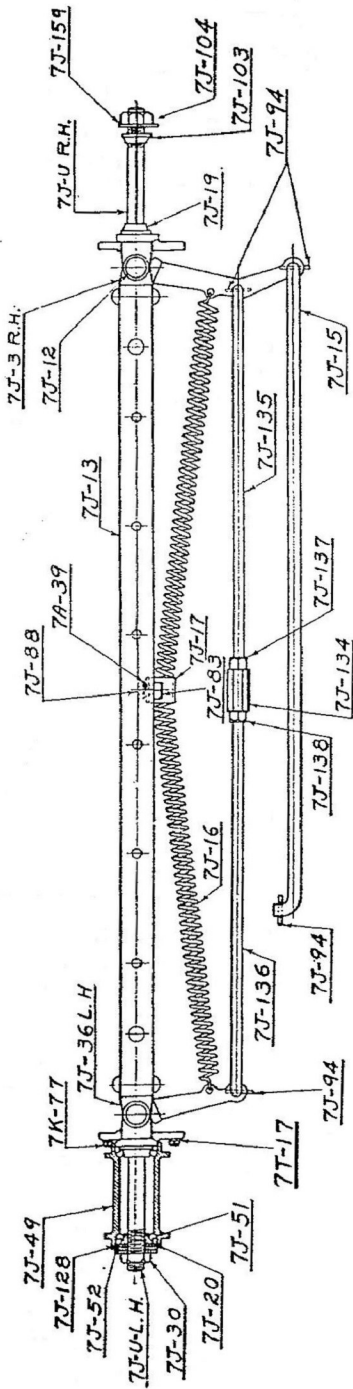

SEE DESCRIPTION FOR ASSEMBLY NUMBERS

7J-B, 7J-C, 7J-U, 7J-V

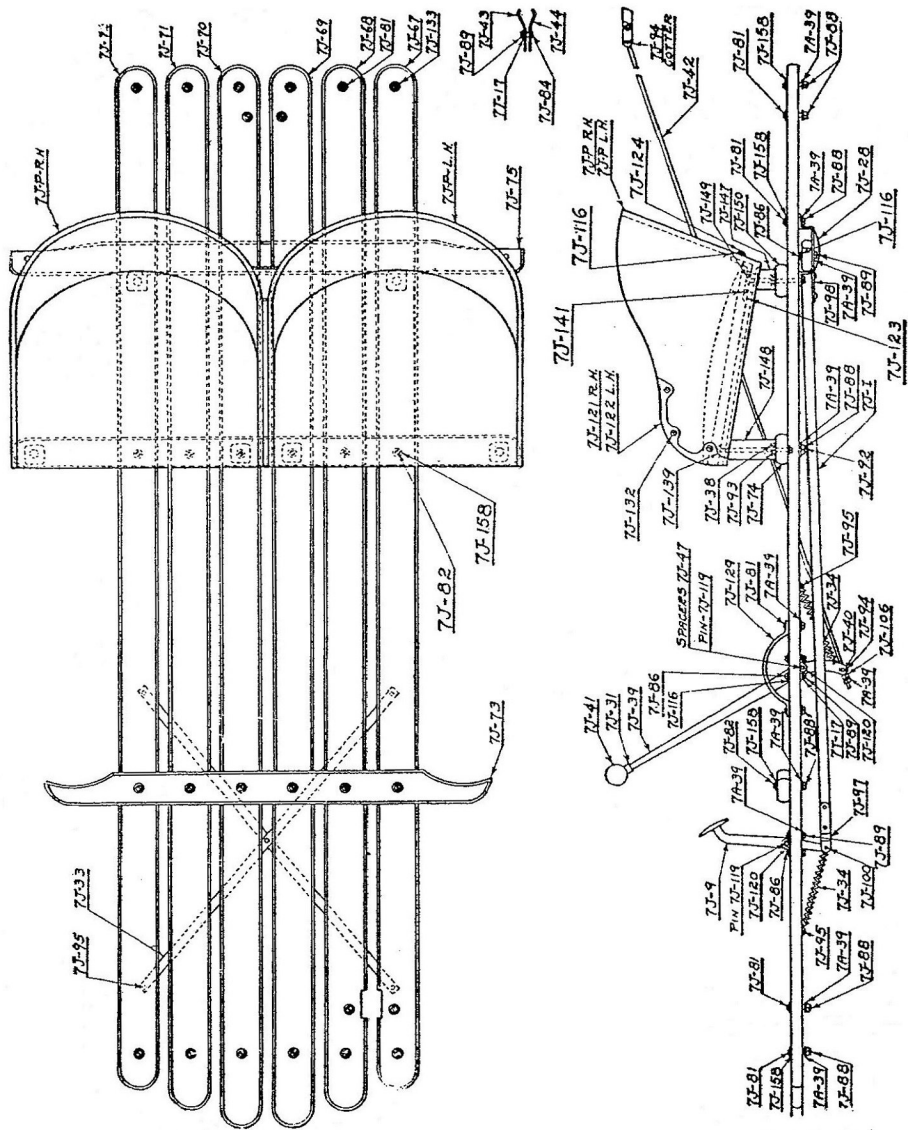

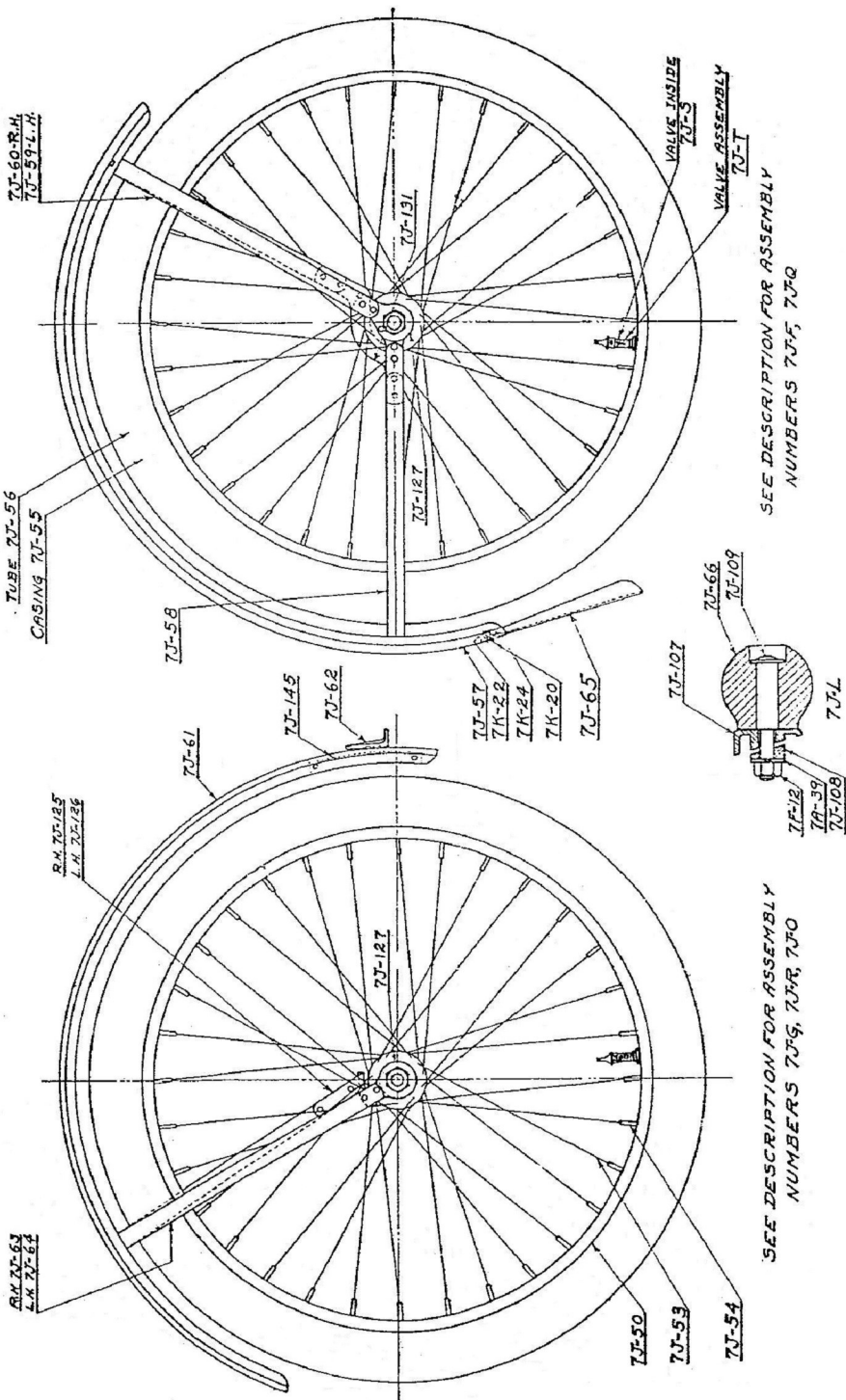

SEE DESCRIPTION FOR ASSEMBLY  
NUMBERS 7J-5, 7J-6

SEE DESCRIPTION FOR ASSEMBLY  
NUMBERS 7J-9, 7J-10, 7J-11

Read instructions "How to Order." Always give MOTOR NUMBER when ordering parts.

Give part number and full description on order.

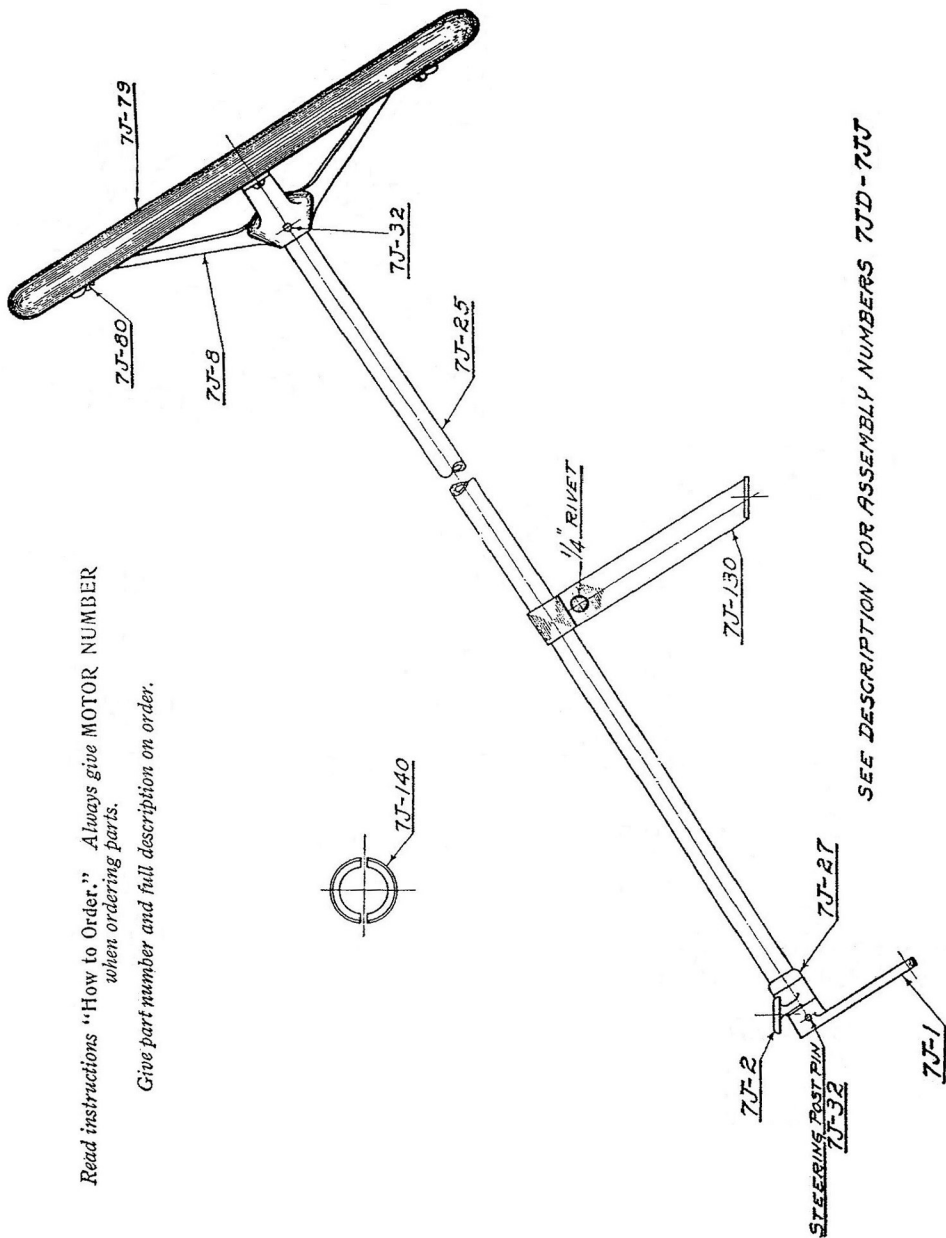

SEE DESCRIPTION FOR ASSEMBLY NUMBERS 7JD-7JU