

**OPERATING AND  
MAINTENANCE MANUAL  
WITH PARTS CATALOG**

**PRICE 10¢ EACH**

**For Briggs & Stratton Engine  
MODEL  
"5S"**



**MANUFACTURED BY  
BRIGGS & STRATTON CORPORATION  
MILWAUKEE 1, WISCONSIN, U. S. A.**

# IMPORTANT SAFETY INFORMATION AND INSTRUCTIONS FOR ENGINE SELECTION ENGINE INSTALLATION ENGINE OPERATION

In the USA and Canada,  
our 24 hour hotline is:

18002333723

Briggs & Stratton Corporation  
Milwaukee, Wisconsin 53201

[www.briggsandstratton.com](http://www.briggsandstratton.com)

Keep these instructions for future reference.



**Before installing and operating this engine read and observe all warnings, cautions and instructions on both sides of this sheet, on the engine, and in the operating & maintenance instructions.**

**NOTE:** This sheet of instructions and safety information is not meant to cover all possible conditions and situations that may occur. Read entire Operating & Maintenance Instructions for this engine AND the instructions for the equipment this engine powers. Failure to follow instructions and safety information could result in serious injury or death.

The safety alert symbol () is used to identify safety information about hazards that can result in personal injury.

A signal word (DANGER, WARNING, or CAUTION) is used with the alert symbol to indicate the likelihood and the potential severity of injury. In addition, a hazard symbol may be used to represent the type of hazard.

 **DANGER** indicates a hazard which, if not avoided, will result in death or serious injury.

 **WARNING** indicates a hazard which, if not avoided, could result in death or serious injury.

 **CAUTION** indicates a hazard which, if not avoided, might result in minor or moderate injury.

**CAUTION**, when used **without** the alert symbol, indicates a situation that **could result in damage to the engine.**

## HAZARD SYMBOLS AND MEANINGS



Fire



Explosion



Moving Parts



Toxic Fumes



Hot Surface



Shock



Kickback

(OVER)

FORM MS-6445-01/03

# ENGINE SELECTION

 <b>WARNING</b>

<b>Failure to select the correct engine could result in fire or explosion.</b>

- Some engines are unique and designed for specific applications or types of equipment. If this engine will be used to build new equipment, contact Briggs & Stratton to ensure that the engine is appropriate for the intended use.  
**Note: For all Go-karts use only a model 136200 series engine, which offers improved safety and performance.**
- Replacement engines should be the same model as the original engine, or be the Briggs & Stratton designated replacement engine. Refer to the Operation & Maintenance Instructions for engine identification information.  
**Note: For all Go-karts use only a model 136200 series engine, which offers improved safety and performance.**
- Do not use Briggs & Stratton engines on 3-wheel All-Terrain Vehicles (ATVs), motor bikes, air craft products, or vehicles intended for use in competitive events. Briggs & Stratton does not approve of or authorize such uses.

# ENGINE INSTALLATION

- [1] Do not attempt to install this engine if you do not have the appropriate tools and knowledge of small engine installation procedures. Use only Briggs & Stratton parts. Contact your Authorized Service Dealer for assistance.
- [2] Do not modify the engine in any way without Briggs & Stratton factory approval. Any such modification is at the owner's sole risk.
- [3] If the exhaust system on the old engine was supplied by the equipment manufacturer, you must transfer the exhaust system and related components (original muffler and related pipes, brackets, clamps, and shields) to the new engine. All components must be in good condition.
- [4] 

 <b>WARNING</b>	Install muffler (and muffler deflector if used) so outlet points away from operator, fuel tank, and equipment, and so muffler heat will not damage or deform engine and components.
	
- [5] 

 <b>WARNING</b>	Ensure all fuel lines and fittings are properly assembled and do not leak. Replacement parts must be the same model as the original.
	
- [6] 

 <b>WARNING</b>	Ensure all wiring, including safety switches and engine shut-off components are completely installed and functioning properly.
	
- [7] Set engine speed to equipment manufacturer's specification. Refer to equipment manufacturer's manual. Do not tamper with governor springs, or other parts that will increase engine speed above specification.

- [8] 







 <b>WARNING</b>	All engine parts, including fuel cap, spark plug, muffler, air cleaner, and covers and guards for drive components (gears, belts, shafts, couplings, etc.) must be in place before attempting to start engine.
	
- [9] 

 <b>WARNING</b>	If engine is installed on walk behind lawn mower, all mower components, including cutting blade, must be correctly installed before attempting to start engine.
	
- [10] 

 <b>WARNING</b>	When working on the engine or equipment, remove spark plug wire from spark plug. For electric start, remove negative wire from battery.
	
- [11] 

 <b>WARNING</b>	Do not check for spark with spark plug removed. Use Briggs & Stratton spark tester #19368.
	

# ENGINE OPERATION

	 <b>WARNING</b>
	<b>When adding fuel:</b>
<p>Turn engine off and let engine cool at least 2 minutes before removing gas cap.</p> <p>Fill fuel tank outdoors or in well-ventilated area. Fill tank to about 1 inch below lowest portion of neck to allow for fuel expansion.</p> <p>Keep gasoline away from sparks, open flames, pilot lights, heat, and other ignition sources.</p>	
	 <b>WARNING</b>
	<b>When starting engine:</b>
<p>Remove all external equipment/engine loads.</p> <p>Wait until spilled fuel is evaporated. Start engine outdoors.</p> <p>Pull cord slowly until resistance is felt, then pull rapidly.</p> <p>If engine floods, set choke to OPEN/RUN, place throttle in FAST and crank until engine starts.</p>	
	 <b>WARNING</b>
	<b>When operating equipment:</b>
<p>Do not tip engine or equipment at angle which causes gasoline to spill.</p> <p>Run engine outdoors. Do not run in enclosed area, even if doors or windows are open.</p> <p>Do not choke carburetor to stop engine.</p>	

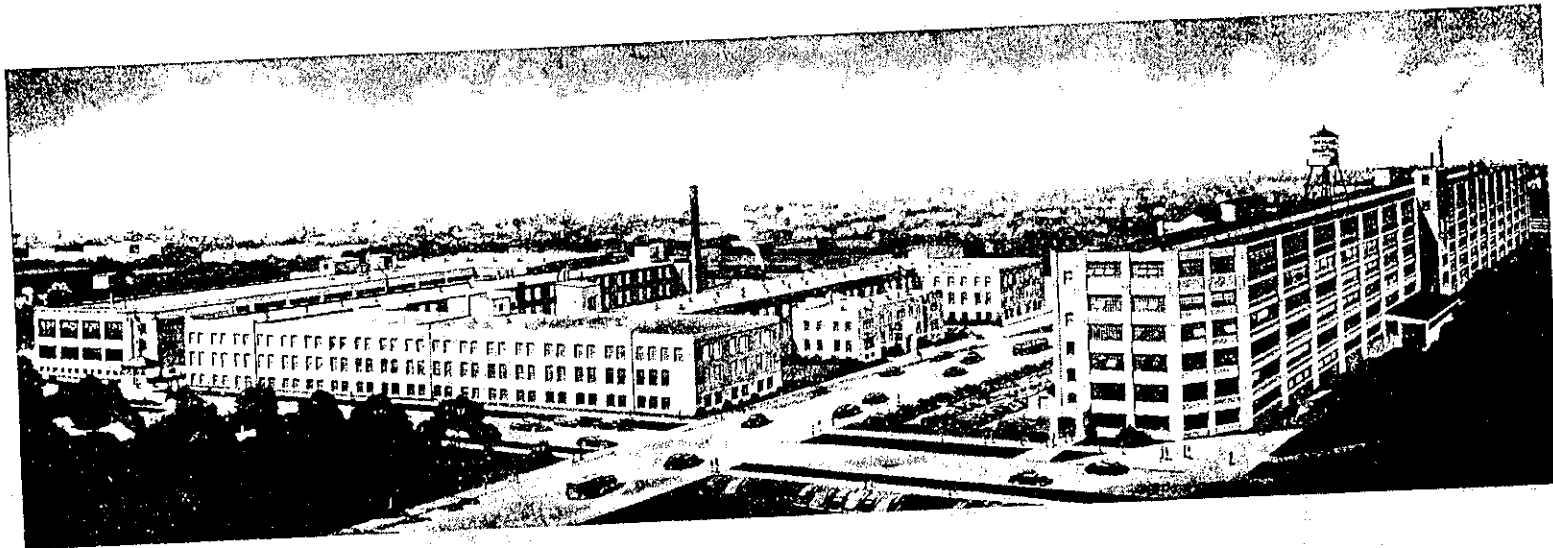

### **WHERE BRIGGS & STRATTON ENGINES ARE MADE**

These large and modern factory buildings, located in Milwaukee, Wisconsin, are complete with all modern equipment and machinery for precision construction, economical production, rigid inspection, and thorough testing of Briggs & Stratton 4-cycle gasoline engines.

Briggs & Stratton Corp. produces more 4-cycle single cylinder air-cooled gasoline engines than any other manufacturer in the world.

## CONTENTS

	Page
<b>Introduction</b> .....	<b>2</b>
<b>Caution</b> .....	<b>2</b>
<b>General Information</b> .....	<b>3</b>
<b>Operator's Section</b>	
a. Preparation for Use.....	4
b. How to Start.....	4
c. Lubrication .....	5
d. Storage Instructions .....	5
<b>Maintenance Section</b>	
a. Engine Trouble Chart.....	6
b. Servicing Reference Chart.....	7
c. Disassembling the Engine.....	8
d. The Fuel System.....	9
e. The Governor .....	10
f. The Ignition System.....	10
g. Valves .....	12
h. Cylinder .....	14
i. Crankshaft .....	14
j. Cam Shaft and Cam Gear.....	14
k. Piston Assembly and Connecting Rod	15
l. Crankcase Breather Valve.....	15
<b>Parts Section</b>	
a. How to Find Correct Part Number..	17
b. Illustrations of Parts.....	18-20
c. Parts List .....	21-25
d. How to Order Repair Parts.....	29
e. Warranty .....	29
f. Authorized Service Organization.....	Back Cover

## INTRODUCTION

This book has been especially prepared to cover the Engine Models listed on the cover and is published for the information and guidance of all concerned.

**THERE IS A RIGHT WAY TO OPERATE THIS ENGINE. THIS BOOK TELLS YOU HOW.**

Guessing how to run it may cause failure to receive the maximum in performance and dependable service originally built into this engine. Each engine has been carefully tested and adjusted at the factory before packing for shipment, and if correctly operated will perform efficiently and economically.

This book is divided into four sections, namely:

1. **GENERAL**, contains information that you should know regarding the principal specifications and design of the engine.
2. **OPERATOR'S SECTION**, contains instructions necessary for starting and operating the engine.
3. **MAINTENANCE SECTION**, consists of instructions pertaining to actual repairs such as are conducted in the repair shop.
4. **PARTS SECTION**, includes exploded views of the various engine assemblies and component parts and parts list.

## CAUTION!

1. Exhaust gases contain carbon monoxide which is odorless and a deadly poison. Proper care must be taken to provide efficient ventilation.
2. Fill crankcase and air cleaner with proper oil before starting engine. See that oil level is maintained.
3. Do not fill the gasoline tank while the engine is running. Avoid spilling gasoline on a hot engine—this may cause an explosion and serious injury.
4. This engine is air cooled. The fan action of the vaned flywheel forces cooling air between the fins of the cylinder and cylinder head which keeps the engine at its proper operating temperature.

Lack of air due to clogging of blower screen, flywheel vanes, or cylinder and cylinder head fins causes overheating which may result in serious damage such as warped or cracked cylinder head, ignition failure, burnt valves, sticking rings, scored piston, bearing failures, etc.

When the air entering the cooling system carries a considerable amount of foreign matter such as grass or heavy dirt, the cooling system can become restricted or clogged in a very short time and regular cleaning is required.

It is recommended that frequent inspection be made during use to determine how often cleaning is necessary. If this is done, the air cleaner serviced properly, and the engine operated on a good grade of gasoline and oil, you may expect trouble-free performance indefinitely. The life of your engine is in direct ratio to the care it receives.

## GENERAL INFORMATION

This engine is a single cylinder, L-Head air-cooled type; bore 1" and stroke 1 1/4". It is rated at:

.85 H.P. at 2200 R.P.M.  
1.0 H.P. at 2700 R.P.M.  
1.1 H.P. at 3200 R.P.M.

(The horsepower ratings listed above are established by standard I.C.E.I. procedures. For practical operation, the horsepower loading should not exceed 85 per cent of these ratings. Engine power will decrease 3 per cent for each 1,000 feet above sea level, and 1 per cent for each 10 degrees above 60 degrees F.)

It is of the same basic 4-cycle design used in automobiles, aircraft, trucks, and tractors. As the name indicates, there are four strokes to one complete power cycle:

### THE 4-STROKE CYCLE Plate No. 1

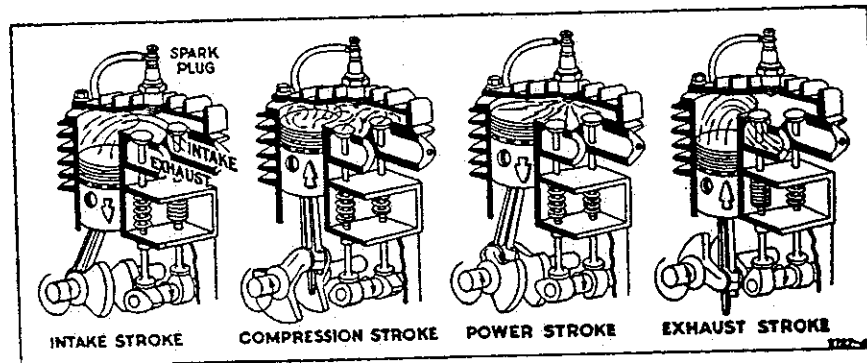

- a. **INTAKE STROKE:** The piston goes down, creating a vacuum in the cylinder which draws gas through open intake valve into the space above the piston.
- b. **COMPRESSION STROKE:** The piston comes up with both valves closed, highly compressing the gas into the space left between the top of the piston and cylinder head.
- c. **POWER STROKE:** At this point the magneto sends high tension current to the spark plug, firing or exploding the compressed gas and driving the piston down.
- d. **EXHAUST STROKE:** Exhaust valve opens and the upward stroke of the piston forces out all of the burnt gases, thus completing the power cycle.

Ignition is supplied by a high tension magneto built into the flywheel. The spark plug is 14mm.

Lubrication is supplied by a splash system which furnishes positive lubrication to all moving parts. Oil reservoir capacity is 1 pint.

The fuel tank holds one quart. The carburetor is suction type.

The governor is adjustable pneumatic type.

Two valves are employed: one Intake and one Exhaust.

The piston and connecting rod are made of aluminum alloy. Crankshaft is a drop forging, counterweighted to reduce vibration.

This engine has been substantially built. It is made of high grade materials by skilled workmen, in a factory fully equipped with the most modern machinery. Before it was shipped, it received many tests and careful inspections.

## OPERATOR'S SECTION

### STARTING AND OPERATING INSTRUCTIONS

#### 1. PREPARATION FOR USE.

a. Before starting the engine, fill the crankcase with Mobiloil Arctic or other high grade oil not heavier than S. A. E. No. 20 for operating the engine in temperatures of 32° F. or above. For temperatures below 32° F. use Mobiloil Arctic Special S. A. E. No. 10W or other high grade oil.

The oil filler cap is located at end of engine base. To open, tilt cap up on one side as shown in insert below until "catch" holds the cap open. Do not pull entire cap up as this may over-stretch the spring. In this position cap will stay open. With the engine standing level pour oil in opening until it rises to the top of filler cap opening. The crankcase holds one pint. To close, roll cap with thumb and it will snap into place. When closed be sure cap is flat as shown in plate below. Some engines have screw plug for oil filler cap. Use a screwdriver or rod to loosen plug.

b. Fill air cleaner with same oil as used in the crankcase and fill to the indicated oil level. Clean out and refill every 25 hours. Change oil hourly under dusty operating conditions.

c. Fill the fuel tank with a good grade of regular, clean, fresh gasoline such as Mobilgas. DO NOT MIX OIL WITH GASOLINE.

#### 2. HOW TO START ROPE STARTER.

a. Completely close carburetor choke by pushing choke lever in (see Plate No. 2).

b. Wind the starter rope around the starter pulley with the knot in the pulley notch. Pull the rope with a quick steady pull to spin the magneto flywheel with choke fully closed to prime the engine. Then open choke about one-eighth and repeat operation.

Plate No. 2

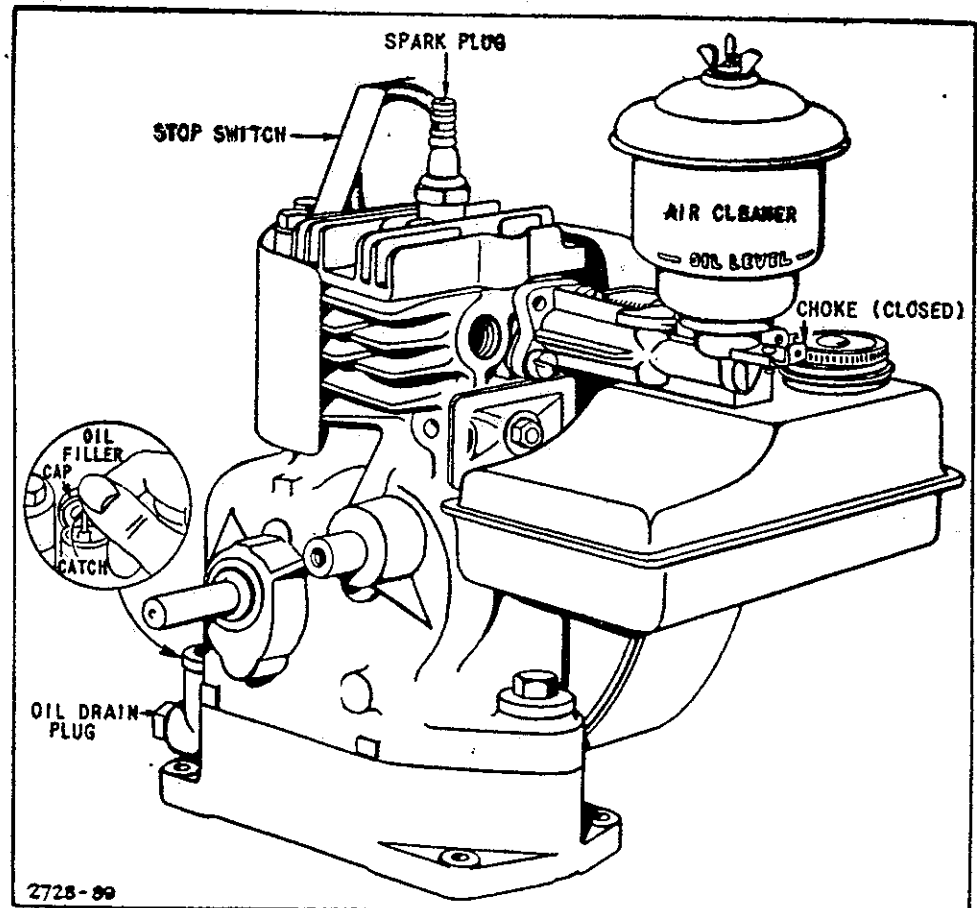



c. After the engine warms up, gradually open choke lever by pulling out until engine runs smoothly with the choke wide open. (A warm engine does not require as much choking as a cold one.)

**RETRIEVABLE STARTER.** Pull fast on rope and return slowly. Keep firm grip on starter ball until fully returned. Operate choke as in paragraphs a and c.

**3. FAILURE OF THE ENGINE TO START.** Cold weather causes the oil in the crankcase to become thick and the gasoline less volatile. Should you experience trouble in starting after spinning the engine several times with the choke closed, be sure to check the spark plug—see that it is clean and the gap set to .025". If the engine fails to start after a reasonable number of trials, do not make any adjustments until you have studied the Engine Trouble Chart on the following page.

**4. HOW TO STOP.**

a. Press the stop switch mounted on the cylinder head against the end of the spark plug. Hold until engine stops firing.

**5. USE CLEAN GASOLINE.** A good grade of regular gasoline is recommended. Be sure the vent hole in the top of the fuel tank cap is open, for air must enter the tank to allow the gasoline to flow to the carburetor.

**6. DO NOT MIX OIL WITH GASOLINE.** This engine is provided with an efficient

splash system which throws oil to all moving internal engine parts.

**7. CHANGE OIL AFTER FIRST 5 HOURS OF OPERATION.** After the first 5 hours of engine operation, drain and refill crankcase. Thereafter, change oil after each 25 hours of engine operation as explained in paragraph No. 9.

**8. ADD OIL REGULARLY.**

**CRANKCASE:** After each 5 HOURS of operation, fill to the top level of the oil filler cap.

**9. CHANGE OIL FREQUENTLY.** After each twenty-five hours of engine operation, the oil should be completely drained from the crankcase. Do not remove engine from its mounting base. Remove the oil drain plug, located at end of engine base (see Plate No. 2), and let the oil flow into a pan or other receptacle. Do not flush out with kerosene. Replace the drain plug, refill with fresh oil, and close the filler cap.

**10. KEEP THE ENGINE CLEAN.** It will pay you to keep the engine clean both inside and outside. See that no dirt or water enters engine when filling with oil or gasoline. As a precautionary measure always wipe off the fuel cap and oil filler plug, as well as around them before refilling. Dirt in the engine or fuel tank will cause trouble and even serious damage. Also be sure to remove any dirt or grass that may accumulate in the flywheel housing or between cylinder fins.

**STORAGE INSTRUCTIONS**

Engines stored any length of time should be completely drained of fuel to prevent gum deposits forming on essential parts such as the carburetor and tank.

Such deposits may affect the operation of the engine when again used. Therefore, it is important that the following instructions be adhered to before storing the engine:

- a. Remove tank and carburetor from unit and drain completely.
- b. Replace tank and carburetor.
- c. Remove spark plug, pour one ounce of S. A. E. No. 20 oil into cylinder and crank slowly to spread oil. Replace spark plug.

**MAINTENANCE SECTION****ENGINE TROUBLE CHART****ENGINE DIFFICULT TO START**

1. No fuel in tank.
2. Fuel flow obstructed.
3. Loose or defective wiring.
4. Spark plug cracked.
5. Spark plug fouled.
6. Improper choking.
7. Improper fuel mixture.
8. Throttle valve stuck or out of adjustment.
9. Throttle rod loose.
10. Valve seats bad.
11. Valves sticking.
12. Timing improper.
13. Defective magneto.
  - a. Breaker points worn or pitted.
  - b. Breaker points out of adjustment.
  - c. High tension wire shorted.

**ENGINE MISSING**

1. Spark plug fouled
2. Spark plug cracked.
3. Spark plug gap wrong.
4. Defective wiring.
5. Ignition breaker points sticking.
6. Valve warped, broken, or sticking.

**ENGINE LOSING POWER**

1. Carburetor choke valve partly closed.
2. Improper fuel mixture.
3. Piston rings sticking.
4. Improper Timing.
5. Muffler clogged.
6. Overload.
7. Cooling air stream obstructed.

**ENGINE KNOCKS**

1. Carbon in cylinder.
2. Loose main bearings.
3. Loose rod bearings.
4. Worn piston and cylinder.
5. Engine overheated.
6. Tight pistons.
7. Loose flywheel.
8. Lack of oil.

**FAULTY CARBURETION**

1. Carburetor improperly adjusted.
2. Sediment or water in fuel tank.

**EXCESSIVE SMOKE FROM EXHAUST**

1. Carburetor needle valve open too far.
2. Worn piston or piston rings.

**EXPLOSION IN CARBURETOR**

1. Gas mixture too lean.
2. Intake valve sticking.
3. Intake tappets sticking.
4. Intake valve spring weak.
5. Intake valve warped or broken.
6. Intake tappets set too close.

**POOR COMPRESSION**

1. Valves not seating.
2. Valves sticking.
3. Piston rings worn or weak.
4. Piston rings broken.
5. Piston rings sticking.
6. Loose spark plug.
7. Cylinder head loose.
8. Scored cylinder.
9. Worn piston and cylinder

**SERVICING REFERENCE CHART**

<b>STARTING AND OPERATING INSTRUCTIONS</b>	Paragraph	<b>VALVES</b>	Paragraph
Preparation for Use.....	1	Valve Adjustments .....	36
How to Start.....	2	To Remove .....	37
Failure of Engine to Start.....	3	Valve Seating .....	38
How to Stop.....	4	Valve Timing .....	39
Use Clean Gasoline.....	5		
Do Not Mix Oil with Gasoline.....	6		
Use the Right Kind of Oil.....	7	<b>CYLINDER</b>	
Add Oil Regularly		The Cylinder Head.....	40
Crankcase .....	8	To Remove and Clean Cylinder Head....	41
Change Oil Frequently.....	9	To Replace Cylinder Head.....	42
Keep the Engine Clean.....	10		
Disassembling the Engine.....	11	<b>CRANKSHAFT</b>	
		To Remove .....	43
		To Check End Play.....	44
<b>FUEL SYSTEM</b>		Oil Seal .....	45
Avoid Gummy Gasoline.....	12		
How to Avoid Gum Formation.....	13	<b>CAM SHAFT AND CAM GEAR</b>	
To Clean Fuel Tank Cap.....	14	To Remove .....	46
Correct Use of Choke.....	15	To Replace .....	47
To Prime the Engine.....	16		
To Adjust the Carburetor.....	17	<b>PISTON ASSEMBLY AND CONNECTING ROD</b>	
To Remove Carburetor.....	18	Piston .....	48
To Replace Carburetor.....	19	Piston Rings .....	49
		Piston Pin .....	50
<b>GOVERNOR</b>		Connecting Rod .....	51
Correct Engine Speed.....	20		
Governor Speed Adjustment.....	21	<b>CRANKCASE BREATHER VALVE</b>	
To Check Governor Blade Clearance....	22	The Breather Valve.....	52
		To Remove and Clean.....	53
<b>IGNITION SYSTEM</b>			
To Check for Spark.....	24	<b>AIR CLEANER</b>	
Spark Plug Adjustment.....	25	To Remove, Clean and Replace.....	54
Ignition Cable .....	26		
To Remove Flywheel.....	27	<b>OVERLOAD</b>	
To Reassemble Flywheel.....	28	To Prevent .....	55
To Remove Magneto Assembly.....	29		
To Replace Magneto Assembly.....	30	<b>REPAIR PARTS INFORMATION</b>	
Magneto Timing .....	31	How to Find Parts You Need.....	56
To Adjust and Clean Contact Point.....	32		
To Replace Condenser.....	33		
To Replace and Adjust Armature.....	34		
Bearing Oil Seal.....	35		

**IMPORTANT NOTICE**

Unless you have a thorough knowledge of internal combustion engines and proper tools, we do not recommend that you attempt to make major engine repairs. This does not mean that you shouldn't make necessary adjustments and simple repairs, but in case of emergency we advise you to get in touch with our nearest service organization. See page 29.

**DISASSEMBLING THE ENGINE**

11. To facilitate the complete disassembly for major repairs, we suggest the following procedure. First drain the fuel and oil and then remove the parts as follows:
  1. Remove air cleaner wing nut and air cleaner.
  2. Take off muffler.
  3. Remove 2 screws holding carburetor to cylinder to remove carburetor.
  4. Remove link from governor blade.
  5. Remove 4 screws holding blower housing and remove housing.
  6. Remove spark plug. Use spark plug wrench.
  7. Remove cylinder head by removing 6 screws which hold it to cylinder.
  8. Remove drive pulley on magneto side of engine.
  9. Take off flywheel and key.
  10. Remove magneto dust cover (2 nuts).
  11. Remove 4 hexagon cap screws which hold magneto plate and remove the magneto assembly.
12. Remove valve cover plate and gasket (1 nut), spray shield and breather parts.
13. Compress valve springs with screw driver and remove pins with pliers to free valves (2).
14. Remove cylinder from base by removing 2 cap screws and washers.
15. Remove 2 cap screws—take off connecting rod cap.
16. Remove carbon at top of cylinder bore, then push out piston and connecting rod assembly.
17. Remove 2 pin locks to remove piston pin from piston.
18. Remove rings from piston.
19. Drive out cam shaft (power take-off side).
20. Remove crankshaft.
21. Remove cam gear and cam followers. Check each item as removed to determine its condition. On following pages you will find instructions for proper repair procedure.

**THE FUEL SYSTEM**

**12. AVOID GUMMY GASOLINE.** If you experience trouble with a gummy, sticky substance with a sharp obnoxious odor, change to fresh gasoline. This gum comes from the gasoline and clogs the carburetor, fuel tank, etc.

**13. YOU CAN AVOID MOST TROUBLE FROM GUM IF YOU WILL KEEP THE FUEL TANK FULL WHEN NOT USING THE ENGINE.** If you use it only occasionally, drain tank completely and refill when the engine is used again. The reason for this is that evaporation of gasoline causes most gum deposits.

**14. TO CLEAN FUEL TANK CAP.** Be sure that the small vent hole in the fuel tank cap is not clogged up, for air must enter the tank to allow the gasoline to flow to the carburetor. Test by blowing through top of cap.

**15. CORRECT USE OF THE CHOKE.** The correct carburetor setting (see Paragraph No. 17) gives the engine the best mixture to run on when it is hot. For starting, it is necessary to choke the carburetor to get a rich mixture, because cold gasoline does not vaporize readily. A warm or hot engine requires very little choking. Until you become familiar with your engine, however, you may make the mistake of not choking the carburetor enough or you may choke it too much. If engine fails to start after cranking three or four times with the choke closed try cranking two or three times with the choke part way open and then all the way open.

**16. TO PRIME THE ENGINE.** The engine may fail to start for the reason that either the carburetor is incorrectly adjusted or dirty, or you are out of gasoline. To determine the cause, prime the engine by removing the spark plug and pour a half teaspoonful of gasoline into the spark plug opening. Replace the spark plug and crank the engine. If it fires for three or four revolutions and stops, the difficulty is definitely in the fuel system. If engine will not fire at all, check the ignition system.

**17. TO ADJUST THE CARBURETOR.** The carburetor on this engine is of the suction type. The gasoline supply is regulated by a needle valve (see Plate 3). The throttle is automatically controlled by the governor. (See paragraph 20.)

a. Adjust carburetor with the fuel tank half full of summer grade "regular" gasoline.

With engine running at normal operating speed (approximately 2700 RPM, no load) turn the needle valve in until engine starts

to lose speed, indicating a lean mixture. Then open needle valve (turn counterclockwise), very slowly until engine just begins to run unevenly. This mixture should be rich enough for good performance under full load.

b. Then test the engine under full load. If it does not carry the load satisfactorily, it usually indicates that the mixture is still too lean and it may be necessary to open the needle valve more in order to further richen the mixture. This richer mixture will cause a slight unevenness in idling.

**Standard Carburetor and Governor Hook-up  
Plate No. 3**

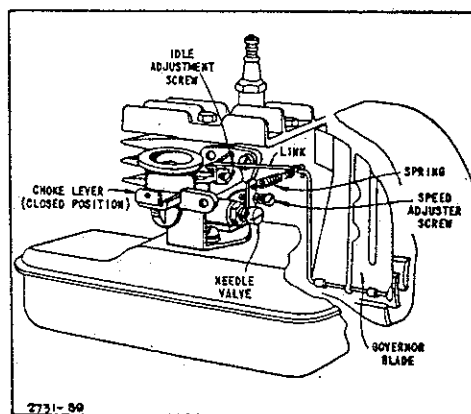

**Remote Governor Control and Hand Control  
Plate No. 4**

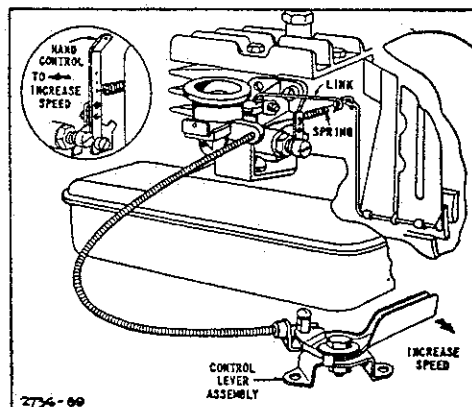

c. Place throttle in idling position. Engine should idle no slower than 1750 RPM, turn idle speed adjusting screw until this speed is reached.

d. When starting cold engine, if it is necessary to keep choke partially closed several minutes before engine runs smoothly.

If carburetor throttle acts sluggish or engine does not govern smoothly, it is usually caused by a dirty or gummy throttle. For governor adjustments see paragraphs 20 and 21.

#### 18. TO REMOVE CARBURETOR.

- a. Remove air cleaner.
- b. Loosen two carburetor mounting screws.
- c. Unhook link at governor blade.

#### 19. TO REPLACE CARBURETOR.

Reverse the operations as performed above. **CAUTION:** Be sure to replace the carburetor gasket. The throttle link must operate freely in the governor arm blade and carburetor throttle arm.

### THE GOVERNOR

**20. CORRECT ENGINE SPEED.** The speed of this engine is automatically maintained under varying loads by a built-in governor. Recommended operating speed is 2200 to 2300 R.P.M. As different types of equipment require various operating speeds for the greatest efficiency, it is suggested that you follow the recommendations of the manufacturer of the complete unit which the engine powers.

#### 21. GOVERNOR SPEED ADJUSTMENT.

The governor was carefully adjusted at the factory to maintain normal speed under load. Do not re-adjust unless absolutely necessary. A speed adjusting screw is located on carburetor. ( See Plate No. 3.)

- a. To increase engine speed, turn screw clockwise.
- b. To decrease engine speed, turn screw counterclockwise.

**HAND GOVERNOR CONTROL.** (See Plate No. 4.) Move lever forward to increase speed.

**REMOTE GOVERNOR CONTROL.** To increase speed move lever on control lever assembly as shown in Plate No. 4.

**22. TO CHECK AIR VANE GOVERNOR BLADE CLEARANCE.** This type of governor has but few parts and seldom do they need replacement because of wear. It is important, however, that the vane has proper clearance so it can operate freely. To check and adjust, proceed as follows:

- a. Remove blower case.
- b. Turn carburetor throttle lever so the throttle is in wide open position. This will enable you to see if the vane clears the armature core and screws. (See Plate No. 5, Fig. A.)
- c. If it does not clear, bend vane bracket or file blade. (See Plate No. 5, Fig. B.)

Do not bend bracket too far or it may rub on flywheel.

#### Governor Air Vane Adjustment Plate No. 5

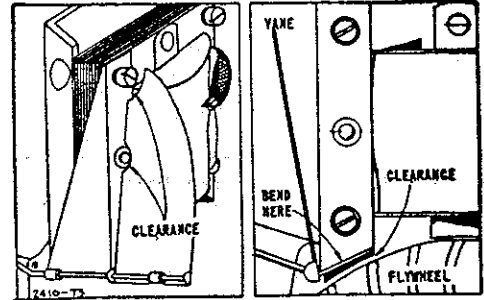

Fig. A

Fig. B

### THE IGNITION SYSTEM

**23. THE IGNITION SYSTEM.** The spark is produced by a high tension magneto consisting of armature, condenser, contact points, and rotating magnets cast in a flywheel. The ignition current is sent into the engine cylinder through the ignition cable and spark plug. The magneto itself as well as the cable and spark plug must all be in proper condition and adjustment to insure a good hot spark.

#### 24. TO CHECK FOR SPARK.

- a. Remove the ignition cable from the plug. Remove plug. Hold the ignition cable terminal about  $\frac{1}{8}$ " from any metal part of cylinder head. (See Plate No. 6.)
- b. Turn engine and if spark jumps this gap the entire ignition system with the exception of the spark plug is O.K.

#### Checking Spark Plate No. 6

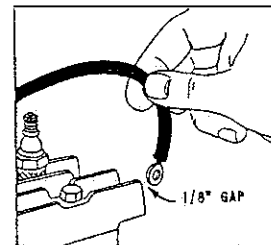

#### Spark Plug Plate No. 7

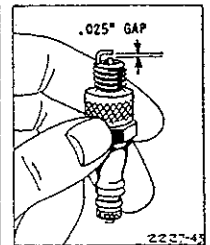

- c. If no spark develops, check the cable (see Paragraph 26), and refer to magneto adjustments explained in Paragraphs 27 to 34.

**25. SPARK PLUG ADJUSTMENT.** The spark plug should be cleaned and the gap reset to .025" after each 100 hours of operation.

(See Plate No. 7.) Always keep a fresh plug on hand. Use Champion No. J-8 (14mm) spark plug or its exact equivalent. When inserting plug place a little graphite grease on the threads.

**26. IGNITION CABLE.** Insulation must not be broken or soaked with oil or water, or grounded in any way where it touches the engine as this will interfere with good ignition. To check the cable all the way to the magneto it is necessary to remove blower case. Be sure that the cable is securely fastened to the secondary terminal of the coil. (See Plate No. 11.)

**27. TO REMOVE FLYWHEEL.** (See Plate No. 8.) The flywheel is securely mounted to the crankshaft by means of a taper fit, a soft key, left hand threaded nut and spring washer. To remove proceed as follows:

**ROPE STARTER ENGINES.**

- a. Remove the blower housing.
- b. Bolt or clamp the engine to a work bench.
- c. Place a block of wood under flywheel fin to hold it solid as illustrated in Plate No. 8.
- d. Use a large wrench, 10" or longer. Turn pulley to the RIGHT until loosened. Be careful not to break fins as this will throw flywheel out of balance.
- e. After the pulley has been removed loosen the flywheel by placing a wood block against the end of crankshaft and strike with a hammer. Pull off flywheel.

Removing Flywheel Rope Starter Engine Plate No. 8

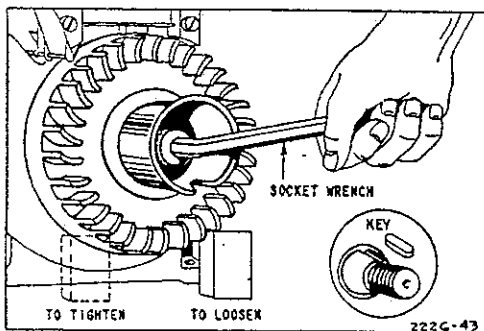

**RETRIEVABLE STARTER.**

- a. Remove blower housing with starter housing attached.
- b. Bend locking tang out of clutch housing recess with screw driver.
- c. Remove clutch housing by tapping to the left with a punch and hammer.

d. Take off clutch housing and locking washer.

e. Remove flywheel same as rope starter explained above.

**28. TO REASSEMBLE FLYWHEEL.**

- a. Thoroughly clean flywheel hole and tapered end of crankshaft.
- b. Apply a light coat of colloidal graphite (Oil-Dag) mixed with lubricating oil to the tapered end of the crankshaft. **DO NOT USE TOO MUCH.**
- c. Turn crankshaft until keyway is up. Then place flywheel on crankshaft and align keyways.
- d. Insert key and push up securely into keyways.
- e. Assemble spring washer with the hollow or concave side next to the flywheel.
- f. Place a block of wood under the left side of flywheel to hold rigid and draw nut very tight.

**29. TO REMOVE MAGNETO ASSEMBLY.**

After the flywheel has been removed as explained in above paragraph, proceed as follows:

- a. Remove magneto point dust cover. It is not necessary to remove the carburetor unless you have already done so.
- b. Remove four magneto plate mounting screws.

**30. TO REPLACE MAGNETO ASSEMBLY.**

Use same gaskets between plate and crankcase, or if damaged, use one of the following new gaskets for proper end play:

- Part No. 67597—.005"
- Part No. 67607—.009"
- Part No. 67307—.015"

The end play should be .002" to .008" between magneto bearing and crankshaft thrust faces as shown in Plate No. 9.

Use lockwashers under mounting screws.

Correct End Play—Plate No. 9

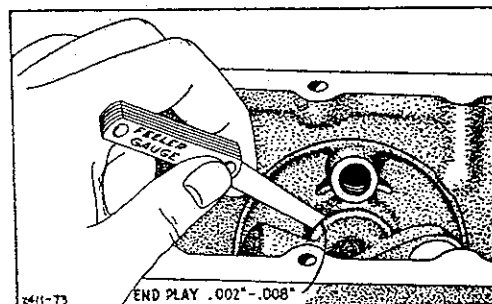

**31. MAGNETO TIMING.** The magneto assembly is always correctly timed with the engine when the flywheel is assembled to the tapered crankshaft with a key and

securely held in place with left hand threaded nut. Do not attempt to change the timing by relocating any parts or filing crankshaft timing flat. Always use soft key Part No. 61760. If steel key is used and flywheel becomes loose it will damage the keyway in the crankshaft.

### 32. TO ADJUST AND CLEAN CONTACT POINTS. (See Plate No. 10.)

- a. Remove blower housing, flywheel, and magneto point dust cover.

Adjusting Contact Points — Plate No. 10

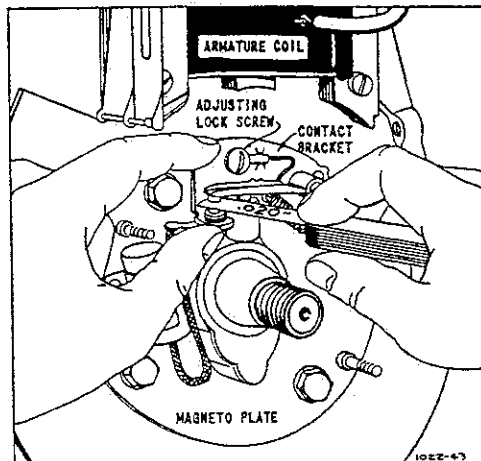

- b. Turn crankshaft by hand to see if contact points open and close properly. Points must be clean and line up squarely to make good contact. Do not file points—use fine sandpaper or fine grit hone to clean points.
- c. Adjust gap to .020" by loosening the adjusting lock screw and moving contact point bracket up or down. When proper gap is

Complete Magneto Assembly — Plate No. 11

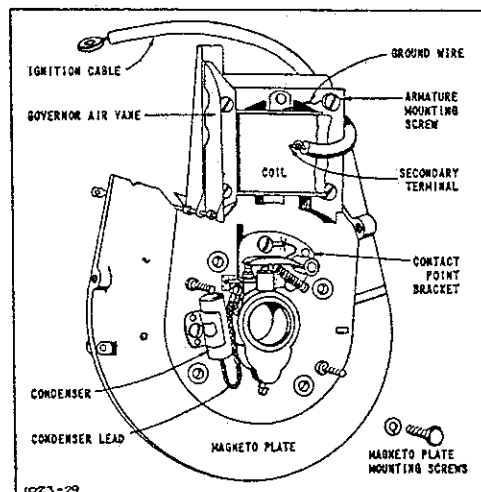

obtained tighten lock screw securely. If either or both points become badly pitted or burned, replace with complete new Contact Point Assembly, Part No. 29667.

33. TO REPLACE CONDENSER. A leaky or weak condenser may cause the engine to start hard, to sputter and misfire under load. If engine misfires after checking the fuel line, carburetor, spark plug, and contact points, install a new condenser, Part No. 29861. Both the condenser lead and armature lead must be fastened to contact bracket. (See Plate No. 11.) Be sure to push condenser lead down between condenser and hub of magneto plate to avoid rubbing against the flywheel.

If after new condenser has been installed the ignition system still does not deliver a satisfactory spark, we recommend sending the complete magneto unit including flywheel to our nearest service organization.

### 34. TO REPLACE AND ADJUST ARMATURE.

- a. Remove primary armature lead wire of coil from brass arm on contact bracket.
- b. Remove high tension ignition cable from secondary terminal in coil.
- c. Unscrew four armature mounting screws.
- d. Install new armature, Part No. 291617, and be sure that condenser lead wire and armature lead wire are fastened to contact bracket. (See Plate No. 11.)
- e. Replace mounting screws, inserting one with terminal of ground wire under screw and draw screws tight.
- f. An air gap of .008" to .012" must be maintained between armature core ends and flywheel. (See Plate No. 12.) Gap must only be sufficient to prevent rubbing, but

Setting Armature Air Gap — Plate No. 12

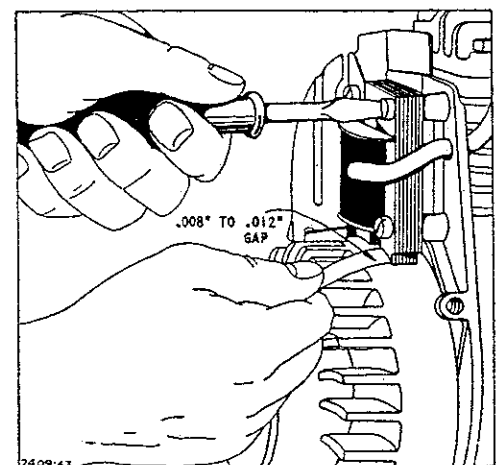



never over .012", or poor ignition will result.

To adjust gap to proper clearance, loosen the four armature mounting screws, slide armature assembly up and place feeler gauge between rim of flywheel and armature core ends. Lower the armature assembly until core ends rest on gauge and lock into place by tightening mounting screws securely.

**35. BEARING OIL SEAL.** A bearing oil seal is mounted in the magneto plate. Use a screw driver to remove but be careful not to damage the bearing surface. This seal is made of a composition and when worn should be replaced with a new one, Part No. 89660. To replace, place seal in the counterbore and force into position with a flat steel block as shown in Plate No. 13.

Replacing Oil Seal — Plate No. 13

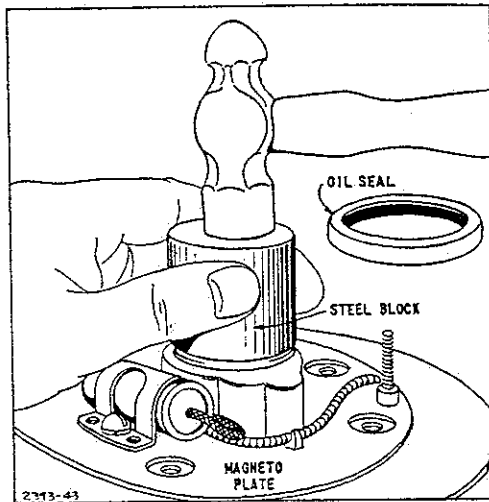

**VALVES**

**36. VALVE ADJUSTMENT.** (See Plate No. 14.) To check valve clearances, remove

Valve Adjustment — Plate No. 14

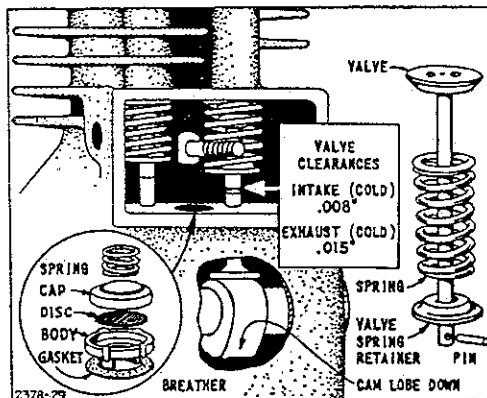

valve cover plate, oil spray shield, and breather valve. The correct valve clearances are as follows when the engine is cold:

- Exhaust Valve — .012"
- Intake Valve — .008"

Tappet clearance is adjusted by grinding required amount from the end of valve stem. End of stem must be square with the stem proper.

**37. TO REMOVE VALVES.**

- a. Drain oil from crankcase of the engine if not disassembled.
- b. Remove cylinder head. (See Par. 40-41.)
- c. Compress valve spring with a screw driver and pull out valve retainer pins with long nosed pliers. Tilt cylinder back far enough to permit the valves to drop with the stems clearing the spring. Pry the spring out with a screw driver.

**38. VALVE SEATING.** Unless valves are properly seated they will cause improper operation due to lack of compression, waste of oil and gasoline. Therefore, reseating valves should be done with the utmost care. They should not be seated by merely lapping with a grinding compound because this is liable to create grooves which wear deeper with use and cause further trouble. To reseat valves, grind in same manner as automobile valves. If valves stick they may be coated with gum or carbon. To remove gum use alcohol or acetone. Clean valve stems thoroughly with wire brush or emery cloth. Also scrape all carbon from valve parts.

a. If the inspection shows that the valve stem is badly worn or the seat is too badly pitted, we recommend sending the engine to our nearest service organization.

**39. VALVE TIMING.** The timing of the valves is taken care of by the meshing of the cam gear with the gear on the crankshaft. These gears are properly meshed when the mark on the cam gear is in line with the mark on the crankshaft collar as shown in Plate No. 15.

Valve Timing — Plate No. 15

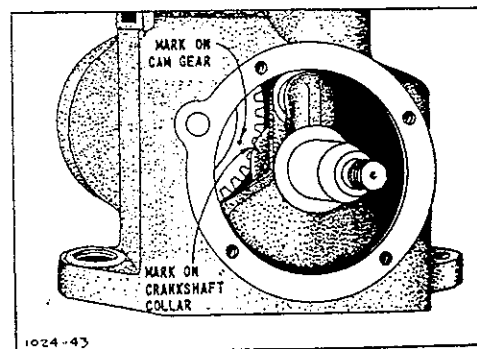

### CYLINDER

**40. CYLINDER HEAD.** The cylinder head is held in place with six cap screws.

**41. TO REMOVE AND CLEAN CYLINDER HEAD.**

- a. Remove spark plug.
- b. Remove cylinder head.
- c. Accumulated dirt, grease, and oil should be scraped and blown out of the air passages. This is important to allow free circulation of air and prevent overheating.
- d. Clean carbon deposits with wire brush or scraper and thoroughly blow out. See that spark plug hole is clean and that the threads are not stripped.

**42. TO REASSEMBLE CYLINDER HEAD.**

- a. Use a new gasket, Part No. 291301. If not available, clean the old one and coat both sides with cup grease — shellac is not recommended.
- b. Replace cylinder head and turn each screw by hand as far as it will go.

Tightening Cylinder Head — Plate No. 16

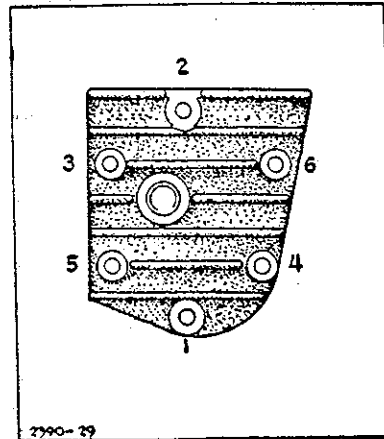

c. Use a socket wrench with a handle not over 6" long and tighten all screws evenly with a  $\frac{1}{4}$  turn in the rotation, 1 to 6, as shown in Plate No. 16. Do not tighten one screw down completely before the others as this may cause the cylinder head to warp or damage the gasket. Run engine two to five minutes.

d. Now tighten all screws snugly (which will usually be about  $\frac{1}{4}$  turn) in the same rotation.

### CRANKSHAFT

**43. TO REMOVE CRANKSHAFT.**

- a. Drain oil from crankcase.
- b. If hand or foot starter, remove starter assembly.
- c. Remove blower housing.

d. Remove pulley washer (turn to right) and key to remove flywheel as explained in Paragraph 17.

e. Remove magneto plate. (See Paragraph 29.)

f. Remove engine from base.

g. Turn engine upside down.

h. Disconnect connecting rod and push piston down in cylinder bore so it clears crankshaft. Do not push too far as top ring may become detached.

i. Remove cam shaft. (See Paragraph 46.)

j. Slide crankshaft out toward the magneto side of the engine.

k. Remove cam gear.

**44. TO CHECK FOR CORRECT END PLAY.**

Use a new gasket when reassembling crankshaft and magneto plate. End play should not be less than .002" or more than .008". (See Paragraph 30.)

**45. OIL SEALS.** If the oil seals are worn or damaged, replace with new ones.

### CAM SHAFT AND CAM GEAR

**46. TO REMOVE CAM SHAFT AND CAM GEAR.**

- a. If hand or foot starter, remove starter assembly.
- b. Remove blower housing.
- c. Remove flywheel and magneto plate.
- d. Use a blunt punch and force cam shaft out from the drive side of the engine as shown in Plate No. 17.
- e. Remove crankshaft. (See Paragraph 43.)
- f. The cam gear will then be free for removal from crankcase after crankshaft has been removed.

Removing Cam Shaft — Plate No. 17

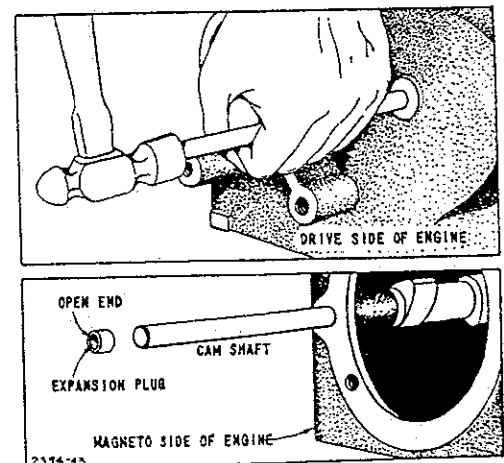

Be sure not to get burrs on the end of the shaft. After the shaft has been removed, check shaft for wear. If worn more than .001", replace with a new shaft.

**47. TO REPLACE.**

a. Insert cam shaft through hole on the magneto side of the engine far enough to permit sliding the cam gear into position. Be sure to line up timing marks as explained in Paragraph 39.

b. Slide cam shaft through cam gear and press in flush with outside of crankcase on the opposite side.

c. Install the extension plug in the hole on the magneto side with its open end out. Seal with "Permatex" or other liquid gasket material to prevent oil leaks.

the cylinder below the piston ring travel. Before assembling new rings to piston be sure that piston ring grooves are thoroughly cleaned and rings move in grooves freely.

**50. PISTON PIN.** The piston pin is a slip fit in the piston. To remove it from the piston, first remove the pin locks, then slip pin out of piston. If pin or hole is worn, replace with oversize pin No. 290981.

**51. CONNECTING ROD.** The connecting rod is also made of a special aluminum alloy which combines strength with light weight. The connecting rod is equipped with a dipper. This is held in place with hexagon head cap screws and lock washers. Assemble as shown in Plate No. 18. The assembly marks on the cap and rod should be on the same side.

**PISTON RINGS, PISTON PIN, AND CONNECTING ROD**

**48. PISTON.** (See Plate No. 18.) The piston in this engine is made of a special alloy which is very light in weight. The lands of the piston are smaller than the skirt to allow for greater expansion at the piston head. This clearance is to compensate for the expansion of the aluminum when hot. When piston is removed be sure to clean carbon from head and ring grooves. If piston is out of round or scored it should be replaced with a new one. If an oversize piston is necessary, we recommend that engine be sent to our nearest service organization.

**CRANKCASE BREATHER VALVE**

**52.** The breather valve used on this engine is mounted in the valve chamber (See Plate No. 14) and consists of the following parts:

- No. 26330 Retainer Spring.
- No. 22216 Cover.
- No. 65968 Valve Disk.
- No. 210028 Valve Body.
- No. 27327 Gasket.

If this becomes clogged it will cause oil leaks. Therefore, it is well that it be checked and cleaned whenever engine is taken apart for service.

**53. TO REMOVE AND CLEAN.**

- a. Remove valve plate cover.
- b. Remove oil spray shield.
- c. Remove retainer spring. (This holds breather valve in place.)
- d. Remove breather valve and wash the parts thoroughly with kerosene or gasoline, blow out and dry.

Replace by reversing the above procedure.

Piston Assembly — Plate No. 18

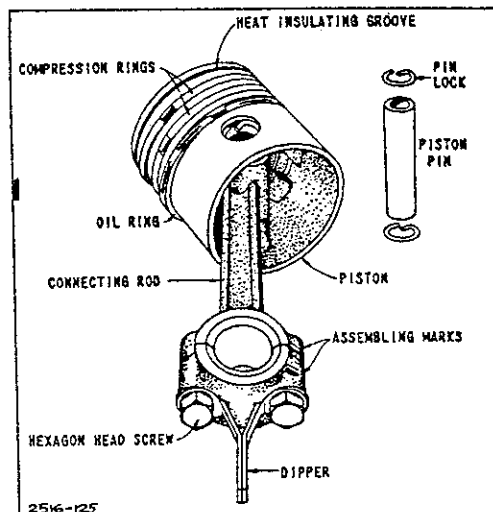

**49. PISTON RINGS.** The piston rings when fitted in the cylinder should have a gap of .007" to .017". The rings should be fitted in

**AIR CLEANER**

**54. TO REMOVE, CLEAN, AND REPLACE.**

(See Plate No. 19.) The air cleaner is to protect the engine from dirt and grit. It is therefore important that it be cleaned and refilled every 25 hours the engine is in use (hourly if operating under dusty operating conditions) to prevent clogging. Clean as follows:

- a. Remove thumb nut and slide entire cleaner over rod.
- b. Remove filter and bowl and pour out oil.

Air Cleaner Assembly — Plate No. 19

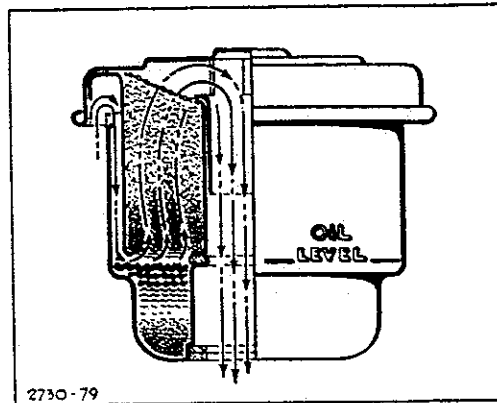

c. Wash the filter element in gasoline. Shake to remove excess gasoline so that

engine will not be flooded when starting.

d. Clean bowl and dry by submerging in gasoline and wipe dry.

e. Replace parts. Fill cleaner with same oil as used in the crankcase up to the level indicated by mark on the outside of the cleaner bowl. Be sure gasket is in place between filter and bowl. See instructions on nameplate.

### OVERLOAD

55. TO PREVENT. Always be sure that the machine the engine is operating is well lubricated and running freely. If it is not, it may cause the engine to be overloaded, resulting in it overheating, losing power, or stopping entirely.

## PARTS SECTION INDEX

How to Find the Correct Number of Part You Need.....(See below)	Page
Illustrations of Parts Groups:	
Cylinder, Piston, Connecting Rod, Crankshaft and Flywheel Parts .....	18
Fuel System, Blower Case and Ignition Parts.....	19
Starter Parts .....	20
Numerical Parts List.....	21 to 25



### 56. HOW TO FIND THE CORRECT NUMBER OF THE PART YOU NEED

a. Make a note of your engine **TYPE NUMBER** (not the Serial Number) that appears on the metal nameplate attached to cylinder shield.

b. Refer to pages illustrating parts and locate the **Master Part Number** by comparing your old part with illustrations. Assemblies include all part numbers shown in frames in illustration. All parts shown in assembly frames on which part numbers are given can be purchased separately.

c. After the **Master Part Number** has been identified, refer to the following **Parts List** where these **Master Part Numbers** are listed in numerical order.

*THE MASTER PART IS USED ON ALL TYPES OF ENGINES EXCEPT THOSE TYPES LISTED UNDER "NOTE."*

d. If a "Note" appears below the **Master Part Number**, this means that this part is made different from the **Master Part** for certain types, and if your type is listed under "Note" order the part referred to.

e. If your **Engine Type Number** does not appear after any part number listed under "Note," order the **Master Part Number**.

f. When ordering parts — or writing for service information — always specify the **MODEL LETTER — TYPE NUMBER —** and **SERIAL NUMBER** of your engine.

g. All parts should be ordered from the nearest member of our **Nation-wide Service Organization**. (See page 29.) In ordering parts by mail, selling prices will be furnished on request or parts will be shipped at prevailing prices.

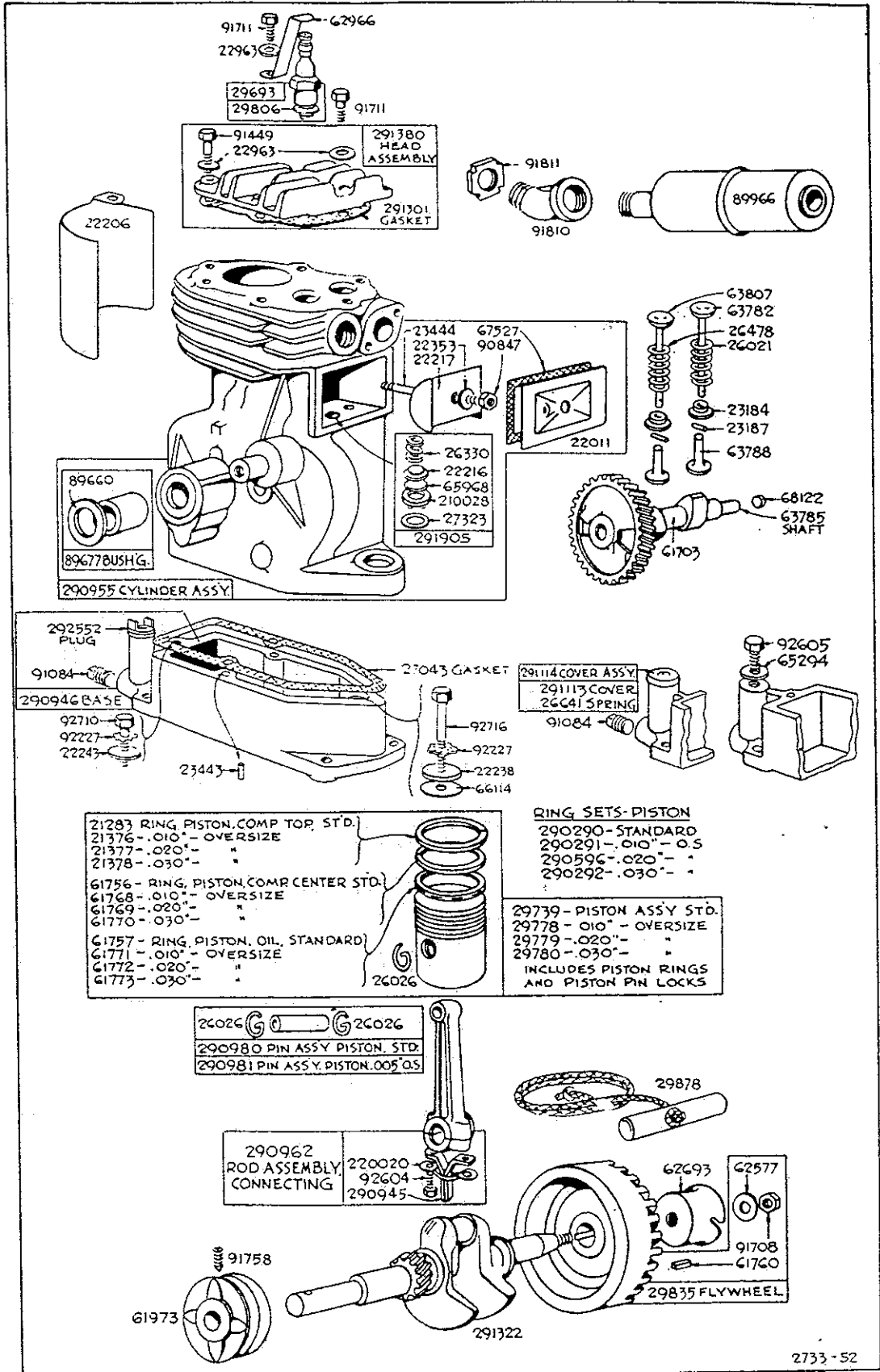

CYLINDER, PISTON, CONNECTING ROD, CRANKSHAFT AND FLYWHEEL PARTS — PLATE No. 20  
Assemblies include all parts shown in frames.

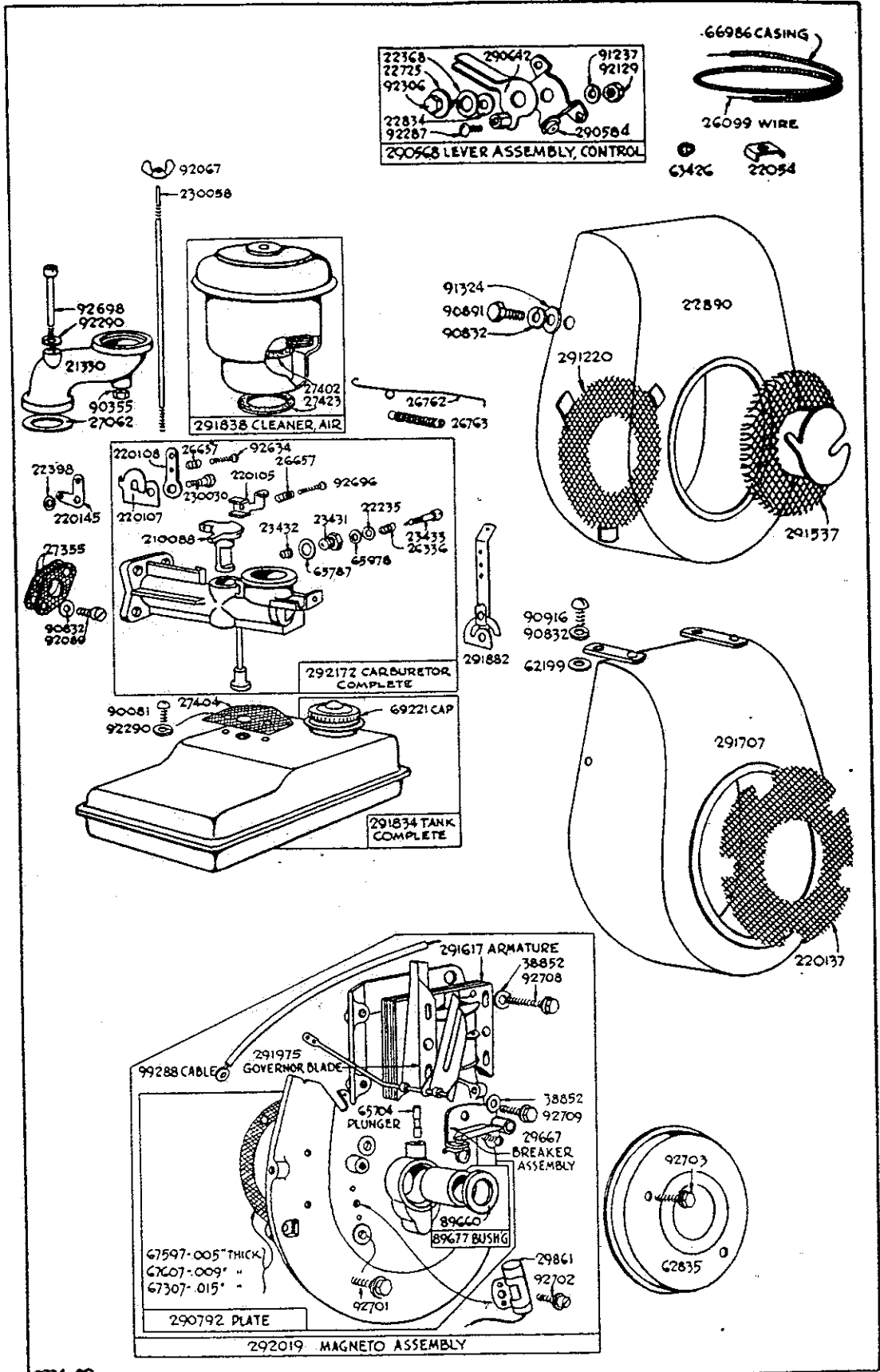

2734-90

FUEL SYSTEM, BLOWER CASE AND IGNITION PARTS -- PLATE No. 21  
Assemblies include all parts shown in frames.

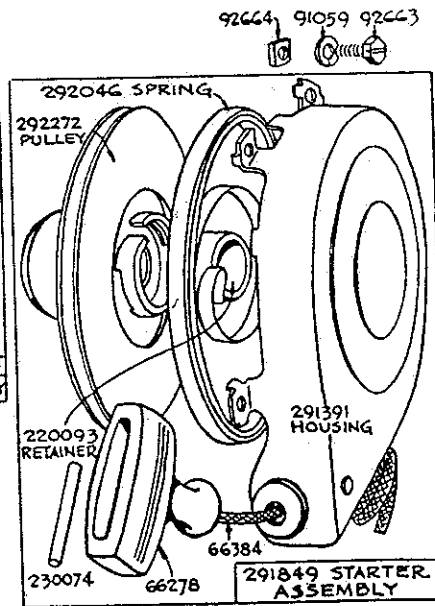
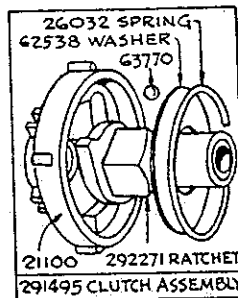
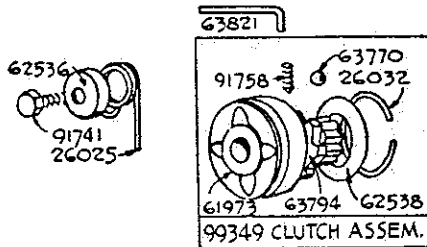
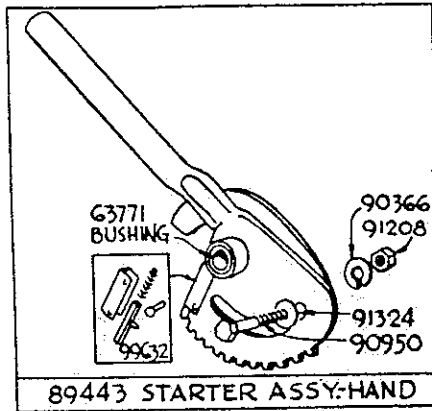

2802-91

STARTER PARTS — PLATE No. 22  
Assemblies include all parts shown in frames.



## NUMERICAL PARTS LIST

MASTER PART NO.	NAME	SHIPPING WEIGHT	
		Lbs.	Oz.
21100	Housing—Starter Clutch .....		14
21283	Ring—Piston, Compression, Top—Standard.....		1
21330	Elbow—Air Cleaner .....		6
21376	Ring—Piston, Compression, Top—.010" O.S.....		1
21377	Ring—Piston, Compression, Top—.020" O.S.....		1
21378	Ring—Piston, Compression, Top—.030" O.S.....		1
22011	Cover—Valve .....		6
22031	Lock—Clutch Housing .....		1
22054	Clamp—Control Wire Casing.....		1
22206	Shield—Cylinder .....		6
22216	Cover—Breather .....		1
22217	Shield—Oil Spray .....		1
22235	Washer—Needle Valve .....		1
22238	Washer—Cylinder Mounting .....		1
22243	Washer—Cylinder Mounting .....		1
*22353	Washer—Valve Cover .....		1
22368	Washer—Control Lever .....		1
22398	Washer—Bell Crank .....		1
22725	Washer—Control Lever .....		1
22834	Washer—Spacer .....		1
22890	Housing—Blower .....	2	
22963	Washer—Cylinder Head .....		1
23184	Retainer—Valve Spring .....		1
23187	Pin—Valve Spring Retainer.....		1
23431	Nut—Needle Valve .....		1
23432	Seat—Needle Valve .....		1
23433	Valve—Needle .....		1
23443	Pin—Dowel .....		1
23444	Stud—Valve Cover .....		1
26021	Spring—Intake Valve .....		1
26025	Spring—Pedal Return .....		1
26026	Lock—Piston Pin .....		1
26032	Spring—Clutch Retainer .....		1
26099	Wire—Control 54" long .....		2
	<i>Note: If longer wire is required, specify length in inches; if shorter wire is needed, order No. 26099 and cut to required length.</i>		
26330	Spring—Breather Retainer .....		1
26336	Spring—Needle Valve .....		1
26478	Spring—Exhaust Valve .....		1
26641	Spring—Oil Hole Cover .....		1
26657	Spring—Choke and Throttle Adjustment Screw.....		1
26762	Link—Governor .....		1
26763	Spring—Governor .....		1
*27043	Gasket—Engine Base .....		1
27062	Gasket—Air Cleaner Mounting.....		1
27323	Gasket—Breather Body .....		1
*27355	Gasket—Carburetor Mounting .....		1
27402	Gasket—Air Cleaner (Cup Shape).....		1
*27404	Gasket—Fuel Tank Mounting .....		1
27423	Gasket—Air Cleaner Mounting .....		1
	<i>*Note: No. 292252 Gasket Set.....</i>		
	<i>Used on engines with plastic bowl air cleaner.</i>		
29667	Breaker Assembly—Ignition .....		1
29693	Plug—Spark—With Gasket.....		3
29739	Piston Assembly—Standard .....		1
29778	Piston Assembly—.010" O.S.....		1

\*Included in Gasket Set — Part No. 292253.

MASTER PART NO.	NAME	SHIPPING WEIGHT	
		Lbs.	Oz.
29779	Piston Assembly—.020" O.S.....		8
29780	Piston Assembly—.030" O.S.....		8
29808	Gasket—Spark Plug .....		1
29835	Flywheel—Magneto .....	6	
29861	Condenser .....		2
29878	Rope—Starter .....		6
38852	Washer—Armature and Breaker Mounting.....		1
61703	Gear—Cam .....	1	8
61758	Ring—Piston, Compression, Center—Standard.....		1
61757	Ring—Piston, Oil—Standard .....		1
61760	Key—Flywheel .....		1
61768	Ring—Piston, Compression, Center—.010" O.S.....		1
61769	Ring—Piston, Compression, Center—.020" O.S.....		1
61770	Ring—Piston, Compression, Center—.030" O.S.....		1
61771	Ring—Piston, Oil—.010" O.S.....		1
61772	Ring—Piston, Oil—.020" O.S.....		1
61773	Ring—Piston, Oil—.030" O.S.....		1
61973	Starter Clutch and Pulley—2 $\frac{3}{4}$ " O.D.....		1
	<i>Note:</i> No. 61781 Pulley—Drive—3 $\frac{1}{4}$ " O.D.....	1	
	Used on type No. 700046.		
62199	Washer—Blower Housing Mounting.....		1
62536	Cup—Starter Return Spring.....		1
62538	Washer—Clutch Retainer .....		1
62577	Washer—Flywheel .....		1
62693	Pulley—Rope Starter .....		6
	<i>Note:</i> For Pulley with screen attached order Part No. 291537.		
62835	Cover—Dust .....		4
62966	Switch—Stop .....		2
63426	Locknut—Control Wire Casing.....		1
63770	Ball—Clutch .....		1
63771	Bushing—Starter Sector .....		1
63782	Valve—Intake .....		2
63783	Shaft—Cam .....		3
63788	Tappet—Valve .....		1
63794	Pinion—Starter .....		4
63807	Valve—Exhaust .....		2
63821	Wrench—Socket Screw .....		2
65294	Gasket—Filler Screw .....		1
65704	Plunger—Breaker Point .....		1
65787	Gasket—Needle Valve Nut.....		1
65968	Disk—Breather .....		1
65978	Packing—Needle Valve .....		1
*66114	Washer—Cylinder Mounting .....		1
66278	Grip—Starter Rope .....		2
66384	Rope—Starter ( $\frac{1}{8}$ " Dia.).....		1
	<i>Note:</i> No. 66334 Rope—Starter ( $\frac{1}{8}$ " Dia.).....		
	Used on earlier model engines.		
66986	Casing—Control Wire—48" long.....		8
	<i>Note:</i> If a longer casing is needed, specify length in inches; if a shorter casing is needed order No. 66986 and cut to required length.		
*67307	Gasket—Magneto Plate—.015" thick.....		1
*67527	Gasket—Valve Cover .....		1
*67597	Gasket—Magneto Plate—.005" thick.....		1
*67607	Gasket—Magneto Plate—.009" thick.....		1
68122	Plug—Cam Shaft .....		1
69221	Cap—Fuel Tank .....		2
89443	Starter Assembly—Hand .....	1	
89680	Seal—Oil .....		1

\* Included in Gasket Set — Part No. 292253.

MASTER PART NO.	NAME	SHIPPING WEIGHT	
		Lbs.	Oz.
89677	Bushing—Cylinder or Magneto..... Includes: No. 89660 Seal—Oil.		8
89966	Muffler .....		8
	<i>Note:</i> No. 292054 Muffler..... Used on type Nos. 700011, 700013, 700016, 700019, 700029, 700033, 700034, 700037, 700042, 700055, 700059, 700064, 700071, 700074, 700078, 700302.		8
90081	Screw—Machine, Rd. Hd.—10-32x $\frac{1}{2}$ ".....		1
90355	Nut—Hex.—No. 10-32 .....		1
90366	Washer—Lock— $\frac{1}{4}$ x $\frac{1}{2}$ x $\frac{1}{4}$ " .....		1
90832	Washer—Lock— $\frac{1}{4}$ x $\frac{1}{2}$ x $\frac{1}{4}$ " .....		1
90847	Nut—Hex.— $\frac{1}{4}$ -28 .....		1
90891	Screw—Cap. Hex. Hd.— $\frac{1}{4}$ -20x $\frac{1}{2}$ " .....		1
90916	Screw—Machine, Rd. Hd.— $\frac{1}{4}$ -20x $\frac{1}{2}$ " .....		1
90950	Screw—Cap, Hex. Hd.— $\frac{1}{4}$ -24x $\frac{3}{4}$ ".....		1
91059	Washer—Lock—No. 12x $\frac{1}{2}$ x $\frac{1}{4}$ " .....		1
91084	Plug—Pipe— $\frac{3}{8}$ " .....		1
91208	Nut, Hex.— $\frac{1}{4}$ -24 .....		1
91237	Washer—Lock— $\frac{1}{4}$ x $\frac{1}{2}$ x $\frac{1}{4}$ " .....		1
91224	Washer— $\frac{1}{4}$ " Standard .....		1
91449	Screw—Cylinder Head (1 $\frac{1}{2}$ " long).....		1
91708	Nut—Flywheel .....		1
91711	Screw—Cylinder Head (1" long).....		1
	<i>Note:</i> No. 91203 Screw—Cylinder Head (1 $\frac{1}{2}$ " long).....		1
	No. 63337 Spacer— $\frac{3}{8}$ " long.....		1
	Used in first hole in cylinder head on carburetor side on type No. 700013 before Serial No. 251216; also used on type No. 700021.		
	No. 91386 Screw—Cylinder Head (2" long).....		1
	No. 63423 Spacer .....		1
	Used to mount bracket to cylinder head on type Nos. 700026, 700054.		
91741	Screw—Pedal Return Spring Cup.....		1
91758	Screw—Set, Socket— $\frac{1}{4}$ -24x $\frac{1}{2}$ " .....		1
91810	Elbow—Exhaust .....		6
	<i>Note:</i> No. 91812 Elbow—Exhaust.....		4
	Used on type Nos. 700014, 700048, 700052, 700061, 700077.		
	No. 91960 Elbow—Exhaust.....		4
	No. 92124 Nipple—Exhaust.....		8
	Used on type No. 700056.		
91811	Locknut—Muffler Elbow .....		2
92067	Nut—Wing .....		1
92089	Screw—Machine, Fill. Hd.— $\frac{1}{4}$ -20x $\frac{3}{4}$ ".....		1
92129	Nut—Hex.— $\frac{1}{4}$ -28 .....		1
92227	Washer—Lock—Shakeproof No. 1120.....		1
92287	Screw—Machine, Rd. Hd.—10-32x $\frac{1}{4}$ ".....		1
92290	Washer—Lock—No. 10x $\frac{1}{2}$ x $\frac{1}{4}$ " .....		1
92306	Screw—Cap, Hex. Hd.— $\frac{1}{4}$ -28x $\frac{3}{4}$ ".....		1
92604	Screw—Connecting Rod .....		1
92605	Screw—Oil Filler .....		1
92624	Screw—Machine, Rd. Hd.—5-40x $\frac{3}{4}$ ".....		1
92663	Screw—Starter Mounting .....		1
92664	Nut—Starter Mounting .....		1
92696	Screw—Machine, Rd. Hd.—5-40x $\frac{3}{4}$ ".....		1
92698	Screw—Machine, Fill. Hd.—10-32x1 $\frac{1}{2}$ ".....		1
92701	Screw—Magneto Mounting Sem.....		1
	<i>Note:</i> No. 90832 Washer—Lock— $\frac{1}{4}$ x $\frac{1}{2}$ x $\frac{1}{4}$ ".....		1
	Used on earlier model engines.		
92702	Screw—Condenser Mounting Sem.....		1
	<i>Note:</i> No. 90367 Washer—Lock—No. 8x $\frac{1}{2}$ x $\frac{1}{4}$ ".....		1
	Used on earlier model engines.		

MASTER PART NO.	NAME	SHIPPING WEIGHT	
		Lbs.	Oz.
92703	Screw—Dust Cover Mounting Sem.....		1
	<i>Note:</i> No. 90367 Washer—Lock—No. 8x $\frac{1}{2}$ x $\frac{1}{4}$ ".....		1
	Used on earlier model engines.		
92708	Screw—Armature Mounting Sem.....		1
	<i>Note:</i> No. 92317 Washer—Lock—Shakeproof No. 1208.....		1
	Used on earlier model engines.		
92709	Screw—Breaker Mounting Sem.....		1
	<i>Note:</i> No. 92317 Washer—Lock—Shakeproof No. 1208.....		1
	Used on earlier model engines.		
92710	Screw—Cylinder Mounting .....		1
	<i>Note:</i> No. 92235 Screw—Cylinder Mounting.....		1
	Used on engines before Serial No. 259868.		
92716	Screw—Cylinder Mounting .....		1
	<i>Note:</i> No. 92236 Screw—Cylinder Mounting.....		1
	Used on engines before Serial No. 259868.		
99288	Cable—Ignition .....		2
99249	Clutch Assembly—Starter .....	1	
99632	Tooth Assembly—Spring .....		1
210028	Body—Breather .....		1
	<i>Note:</i> No. 21310 Body—Breather (with two grooves).....		1
	Used on engines before Serial No. 68505.		
	No. 21310 Body—Breather.....		1
	Used on type No. 700067.		
210088	Throttle—Carburetor .....		1
220020	Lock—Connecting Rod Screw.....		1
220093	Retainer Spring .....		1
220105	Connector—Governor Link .....		1
220107	Cam—Speed Adjuster .....		1
	<i>Note:</i> No. 220134 Cam—Governor Control.....		1
	Used on type Nos. 700014, 700040.		
220108	Lever—Speed Adjuster .....		1
220137	Screen—Blower Housing .....		2
220145	Crank—Bell .....		1
230030	Screw—Carburetor Cam and Lever.....		1
230058	Stud—Air Cleaner .....		2
	<i>Note:</i> No. 23334 Stud—Air Cleaner—6 $\frac{1}{2}$ " long.....		2
	Used on type No. 700014.		
230074	Pin—Starter Grip .....		1
290290	Ring Set—Standard Piston.....		3
290291	Ring Set—.010" O.S. Piston.....		3
290292	Ring Set—.030" O.S. Piston.....		3
290548	Breather Assembly .....		2
290508	Lever Assembly—Control .....		4
290584	Base—Control Lever .....		2
290596	Ring Set—.020" O.S. Piston.....		3
290642	Lever—Control .....		2
290792	Plate—Magneto .....	2	
	<i>Note:</i> No. 290869 Plate—Magneto.....	2	
	Used on type Nos. 700043, 700046, 700070, 700079, 700081.		
290945	Dipper—Connecting Rod .....		4
290946	Base Assembly—Engine .....	1	8
	<i>Note:</i> No. 290938 Base Assembly—Engine.....	1	8
	Used on type Nos. 700053, 700061, 700066, 700075, 700077, 700083.		
290955	Cylinder Assembly .....	13	
	<i>Note:</i> No. 291110 Cylinder Assembly.....	13	
	Used on type Nos. 700012, 700019, 700041, 700042, 700065, 700073, 700078.		
	No. 292026 Cylinder Assembly.....	13	
	Used on type Nos. 700051, 700058.		
	No. 292242 Cylinder Assembly.....	13	
	Used on type No. 700071.		
292496	Cylinder Assembly .....	13	
	Used on type No. 700067.		

MASTER PART NO.	NAME	SHIPPING WEIGHT	
		Lbs.	Oz.
290962	Rod Assembly—Connecting .....		12
290980	Pin Assembly—Piston—Standard .....		2
290981	Pin Assembly—Piston—.005" O.S.....		2
291113	Cover—Oil Hole .....		2
291114	Cover Assembly—Oil Hole.....		2
291220	Screen—Blower Housing .....		2
	Note: No. 291430 Screen—Blower Housing (Full Screen).....		2
	Used on type No. 700302.		
*291301	Gasket—Cylinder Head .....		1
	*Note: No. 67537 Gasket—Cylinder Head ( $\frac{1}{4}$ " Thick).....		1
	Used with cylinder heads having seven fins.		
291322	Crankshaft .....	3	
	Note: No. 26693 Crankshaft.....	3	
	Used on type Nos. 700015, 700020, 700024, 700055, 700081.		
	No. 26716 Crankshaft.....	3	
	Used on type Nos. 700016, 700018, 700021, 700031, 700038, 700042, 700048, 700051, 700054, 700060, 700073, 700077.		
	No. 26779 Crankshaft.....	3	
	Used on type Nos. 700034, 700064, 700071.		
	No. 26780 Crankshaft.....	3	
	Used on type No. 700037.		
	No. 26809 Crankshaft.....	3	
	Used on type No. 700069.		
	No. 291326 Crankshaft.....	3	
	Used on type Nos. 700013, 700019, 700023, 700026, 700028, 700030, 700035, 700036, 700040, 700041, 700043, 700044, 700049, 700050, 700061, 700062, 700065, 700067, 700072, 700074, 700078, 700082, 700083.		
	Uses: No. 23056 Key—Pulley— $\frac{1}{8}$ " Square.....		1
291380	Head Assembly—Cylinder .....	1	8
291391	Housing—Starter .....		12
291495	Clutch Assembly—Starter .....	1	
291498	Rope—Starter .....		4
291537	Screen Assembly—Rotating .....		8
291617	Armature—Magneto .....	2	
291707	Housing—Blower .....	1	4
291834	Tank Assembly—Fuel .....	1	4
291838	Cleaner Assembly—Air .....	1	
291849	Starter Assembly—Retrievable .....	2	
291882	Control—Governor .....		1
291905	Breather Assembly .....		2
	Note: No. 290548 Breather Assembly.....		2
	Used on engines before Serial No. 68505.		
291975	Blade Assembly—Governor .....		6
292019	Magneto Assembly .....	6	
	Note: No. 292146 Magneto Assembly.....	6	
	Used on type Nos. 700043, 700046, 700070, 700079, 700081.		
	Includes: No. 66155 Wire—Ground.....		1
292046	Spring—Starter .....		5
292172	Carburetor Assembly .....	1	
	Note: No. 292173 Carburetor Assembly.....	1	
	Used on type Nos. 700034, 700037, 700049, 700064, 700075, 700076, 700080.		
	No. 292174 Carburetor Assembly.....	1	
	Used on type Nos. 700014, 700040, 700047, 700048, 700061, 700066, 700077.		
292253	Gasket Set .....		4
292271	Ratchet—Retrievable Starter .....		5
292272	Pulley—Retrievable Starter .....	1	
292550	Plug—Oil Filler .....		2

\* Included in Gasket Set — Part No. 292253.

## NATION-WIDE SERVICE ORGANIZATION

To provide prompt and efficient service on Briggs & Stratton engines, Authorized Service Distributors and Engine Service Stations are located in the principal cities of the United States and Canada.

Each Authorized Service Organization carries a stock of original Briggs & Stratton repair parts. Each is equipped with special factory service tools and factory-trained mechanics, assuring expert repair service on all Briggs & Stratton engines.

All Authorized Service Organizations are instructed by the factory to replace free of charge all parts found to be defective in either material or workmanship, according to the conditions of the Briggs & Stratton Warranty.

All gratis work done under the warranty is the responsibility of the Authorized Service Organization until all the material involved and supporting facts are submitted to and approved by the factory.

In a difference of opinion regarding a Service Organization's decision, their terms should be accepted and, either through them or direct, have all materials and supporting facts submitted to the factory for review.

Genuine Briggs & Stratton service will assure continuous engine satisfaction. Our long experience in engine maintenance prompts us to urge that all service work be done by an Authorized Service Organization or at our factory. Mechanics unfamiliar with Briggs & Stratton products, or without proper tools, should not be permitted to make major repairs.

Parts and repair work are F. O. B. Factory or any member of Authorized Briggs & Stratton Service Organization. The Service Distributor nearest you (see back cover page) will be glad to give you the name of our Engine Service Organization in your locality. Space does not permit listing here.

## BRIGGS & STRATTON ENGINE WARRANTY BE SURE TO FILL IN AND MAIL WARRANTY REGISTRATION CARD WHICH ACCOMPANIED ENGINE AT TIME OF PURCHASE

**THE WARRANTY** — For Ninety Days from purchase date, Briggs & Stratton Corporation will replace for the original purchaser, FREE OF CHARGE, any part or parts found, upon examination at any factory Authorized Service Distributor or at our factory at Milwaukee, Wisconsin, to be defective under normal use and service, on account of defects in material or workmanship.

All transportation charges on part or parts submitted for replacement under this warranty must be borne by purchaser.

**WHAT THIS WARRANTY DOES NOT INCLUDE** — This warranty does not cover the free replacement of parts inoperative because of wear occasioned by use. It does not cover the labor cost of replacing parts, neither is it effective if the engine has been the subject of misuse, negligence, or accident, nor if it has been repaired or altered, outside of our Milwaukee Factory or at any factory-approved Service Station, in any way which, in our judgment, affects its condition or operation.

## WARRANTY INSTRUCTIONS

When sending an engine, or engine parts, to a Briggs & Stratton Service Organization for service, at the same time always send by mail the following information:

Model Letter (or Number), Type Number, and Serial Number of the engine. (Take from metal plate on engine.)

Date purchased.

Kind of equipment engine is used on.

Name or trademark of manufacturer.

Name and address of dealer from whom purchased.

Approximate number of hours engine has run since equipment was bought.

Also, give complete report of trouble experienced and special servicing instructions.

The above information is necessary to insure prompt and proper service.

## AUTHORIZED SERVICE ORGANIZATION

There is a member of the Briggs & Stratton Service Organization in your neighborhood who is fully qualified to take care of your service needs. Space does not permit listing here, but if you will write to the nearest distributor listed below, they will be glad to supply you with name and address.

STATE	CITY	NAME	LOCATION
Alabama	Birmingham 3	Birmingham Electric Battery Co.	Ave. B at 23rd St.
Arizona	Phoenix	Motor Supply Co.	402-414 N. Central Ave.
California	Los Angeles 15	Electric Equipment Company	1611 S. Hope St.
California	San Francisco 9	Frank Edwards Co., Automotive Service Div.	382-4 Sixth St.
Colorado	Denver 1	Spitzer Electrical Company	43 W. 9th Ave.
Florida	Jacksonville 1	Spencer Electric, Inc.	40 W. Beaver St.
Florida	Miami 32	Electrical Equipment Co.	42-58 N. W. 4th St.
Florida	Tampa 1	Spencer Auto Electric, Inc.	607-11 E. Cass St.
Georgia	Atlanta 8	Auto Electric & Magneto Co.	477 Spring St., N. W.
Illinois	Chicago 16	Mid-States Auto Electric Co.	1905 S. Michigan Ave.
Indiana	Indianapolis 4	Gulling Auto Electric Co.	450 N. Capitol Ave.
Iowa	Des Moines 9	Magneto Carburetor & Electric Co., Inc.	1308 Grand Ave.
Kansas	Wichita 2	The E. S. Cowie Electric Co.	230 S. Topeka Ave.
Kentucky	Lexington 34	Kentucky Ignition Co., Incorporated	Rose and Vine Sts.
Kentucky	Louisville 2	Kentucky Ignition Co., Incorporated	737 S. 3rd St.
Louisiana	New Orleans 1	A. C. Suhren Co.	4640 So. Carrollton Ave.
Louisiana	Shreveport 80	Chain Battery & Automotive Supply, Inc.	Marshall at Cotton Sts.
Massachusetts	Boston 15	Wm. H. Flaherty Co.	48-52 Cummington St.
Michigan	Detroit 1	Auto Electric & Service Corporation	90 Selden Ave.
Minnesota	Minneapolis 2	Reinhard Brothers Co., Inc.	11 S. Ninth St.
Missouri	Kansas City 8	The E. S. Cowie Electric Co.	1819 Wyandotte St.
Missouri	St. Louis 8	Medart Auto Electric Co., Inc.	3134 Washington Blvd.
Montana	Billings	Original Equipment, Inc.	423 N. Broadway
Nebraska	Lincoln 8	Carl A. Anderson, Inc.	1637 P Street
Nebraska	Omaha 2	Carl A. Anderson, Inc.	16th and Jones St.
New Mexico	Albuquerque	Spitzer Electrical Co. of New Mexico	3rd and Mountain Rd.
New York	Buffalo 14	The Battery & Starter Co., Inc.	2505 Main St.
New York	New York 23	The Durham Co., Inc.	606 W. 49th St.
New York	Syracuse 4	F. A. Crossman, Inc.	943 W. Genesee St.
North Carolina	Charlotte 1	Carolina Rim & Wheel Co.	312 N. Graham St.
North Dakota	Fargo	Reinhard Brothers Co., Inc.	301 N. Pacific Ave.
Ohio	Cincinnati 2	Gardner, Inc.	1847 Reading Rd.
Ohio	Cleveland 15	The Electric Power Maintenance Co.	Prospect at East 30th
Ohio	Toledo 1	The Electric Power Maintenance Co.	26-30 Seventeenth St.
Oklahoma	Oklahoma City 2	American Electric Ignition Co.	124 N. W. 8th St.
Oregon	Portland 9	Tracey & Co., Inc.	N. W. 10th and Glisan
Pennsylvania	Philadelphia 30	Auto Equipment & Service Co., Inc.	1522-24 Fairmount Ave.
Pennsylvania	Pittsburgh 24	Pitt Auto Electric Company	5135 Baum Blvd.
South Dakota	Aberdeen	Reinhard Brothers Co., Inc.	317 S. Lincoln St.
South Dakota	Sioux Falls	Reinhard Brothers Co., Inc.	225 E. 11th St.
Tennessee	Knoxville 7	R. T. Clapp Company	401-7 N. Broadway
Tennessee	Memphis 4	Automotive Electric Service Co.	982 Linden Ave.
Texas	Amarillo	The E. S. Cowie Electric Co.	700 E. 10th St.
Texas	Dallas 1	Beard & Stone Electric Company, Inc.	3909 Live Oak St.
Texas	El Paso	Motor Supply Co.	308 Chihuahua St.
Texas	Houston 1	Beard & Stone Electric Company, Inc.	Milam at Polk Ave.
Texas	San Antonio 6	S. X. Callahan	425 N. Flores St.
Utah	Salt Lake City 13	Frank Edwards Co., Motor Equipment Div.	551 So. State St.
Virginia	Richmond 20	Richmond Battery & Ignition Co.	2912 W. Leigh St.
Washington	Seattle 14	Sunset Electric Co.	300 Westlake North
Washington	Spokane	Sunset Electric Co.	N. 703 Division St.
Wisconsin	Milwaukee 2	Wisconsin Magneto Co.	918 N. Broadway

### DOMINION OF CANADA

Manitoba	Winnipeg	Beattie Auto Electric Limited	176 Fort St.
Ontario	Toronto 5	Auto Electric Service Company, Limited	1009 Bay St.

**BRIGGS & STRATTON CORP., Milwaukee 1, Wis., U.S.A.**