

# Operating Instructions

## MODEL "WMB"

### WASHING MACHINE MOTOR

#### Adjustment and Repair Information Parts List

**IMPORTANT**  
ALWAYS USE  
GOOD, CLEAN OIL  
S. A. E. No. 20  
ADD OIL FREQUENTLY  
CHANGE OIL REGULARLY

**IMPORTANT**  
ALWAYS USE  
GOOD, CLEAN OIL  
S. A. E. No. 20  
ADD OIL FREQUENTLY  
CHANGE OIL REGULARLY

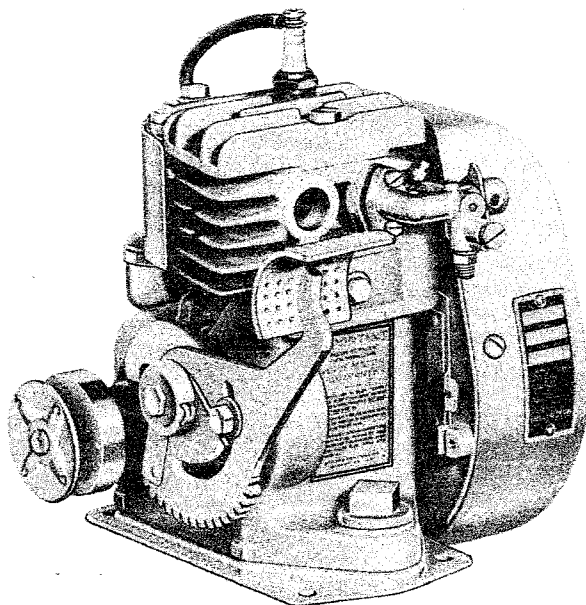

#### INDEX

	Page
Starting the "WMB" Motor.....	3
Servicing Reference Chart.....	4
Instructions for Adjustment and Repair.....	4
Repair Parts .....	10
Parts List .....	11-13
Guarantee .....	13
Illustrated Parts.....	14
Nation-Wide Service Organization.....	15
Authorized Central Service Distributors.....	15

Read these instructions carefully before operating this Motor for the first time.

Guessing how to run it may cause you unnecessary inconvenience, aggravation or failure to receive the fine service that is built into it.

There is a right way to operate the "WMB" Motor. This book tells you how.

Each Briggs & Stratton Motor is carefully tested and adjusted at the factory before packing for shipment, and if correctly operated will perform beyond your expectations.

**DO NOT START THIS MOTOR UNTIL YOU HAVE READ CAREFULLY "STARTING AND OPERATING THE MODEL "WMB" MOTOR" ON PAGE 3**



# Starting the Model "WMB" Motor

	Paragraph		Paragraph
Before Starting the Motor.....	1	How to Stop.....	4
How to Start.....	2	General Data.....	5
Failure of Motor to Start.....	3		

**1. BEFORE STARTING THE MOTOR.** Fill the crankcase with Mobiloil Arctic or any other high grade oil not heavier than S. A. E. No. 20. A HEAVIER OIL MUST NOT BE USED. Remove blue oil filler plug, slowly pour the oil directly on top of the oil drain plug so that the oil runs down the sides of the plug into the reservoir. This will prevent spilling. Crankcase holds  $\frac{1}{3}$  pint. Fill the gas tank with a good, **clean**, third grade gasoline. Tank holds 1 quart. Do not mix oil and gasoline. See paragraphs 11 to 19.

**2. HOW TO START.** Pull up the carburetor choke knob. Step down **quickly** on starter pedal and repeat **rapidly** until motor fires. As the motor warms up, gradually adjust choke until motor operates smoothly. Operate carburetor choke the same as you operate the choke on your automobile. A hot motor does not require as much choking as a cold motor. See paragraph 20.

**3. FAILURE OF MOTOR TO START.** If motor fails to start after a reasonable number of trials do not make any adjustments until you have studied the instructions referred to in the **Servicing Reference Chart**, on page 4.

**4. HOW TO STOP.** Pull the choke knob all the way out and hold until motor stops firing.

**5. GENERAL DATA.** You will find your Briggs & Stratton motor substantially built. It is made of high grade materials by skilled workmen, in a factory fully equipped with the most modern machinery. Before it was shipped, it received many tests and careful inspections.

**6.** Your motor will give you better service if you do not tinker with it. This does not mean, however, that it does not require a certain amount of attention. Give it the right kind of fuel, oil and care. Keep it clean both inside and out. You will be well repaid in trouble-free, satisfactory service.

**7.** If you should experience any difficulty, follow the instructions referred to in the **Servicing Reference Chart** on page 4. If you cannot easily remedy it, consult your dealer, or a nearby Briggs & Stratton Authorized Central Service Distributor. See page 15.

**CAUTION:** To Eliminate the Danger of Deadly Carbon Monoxide Gas, never operate the motor in any room without first installing the exhaust tube with the outlet outdoors at such a point that the poisonous gases will not be carried back into the room by air currents through windows or doors. For proper installation see paragraph 56.

Briggs & Stratton 4-Cycle Motor: Model "WMB" — Plate No. 1

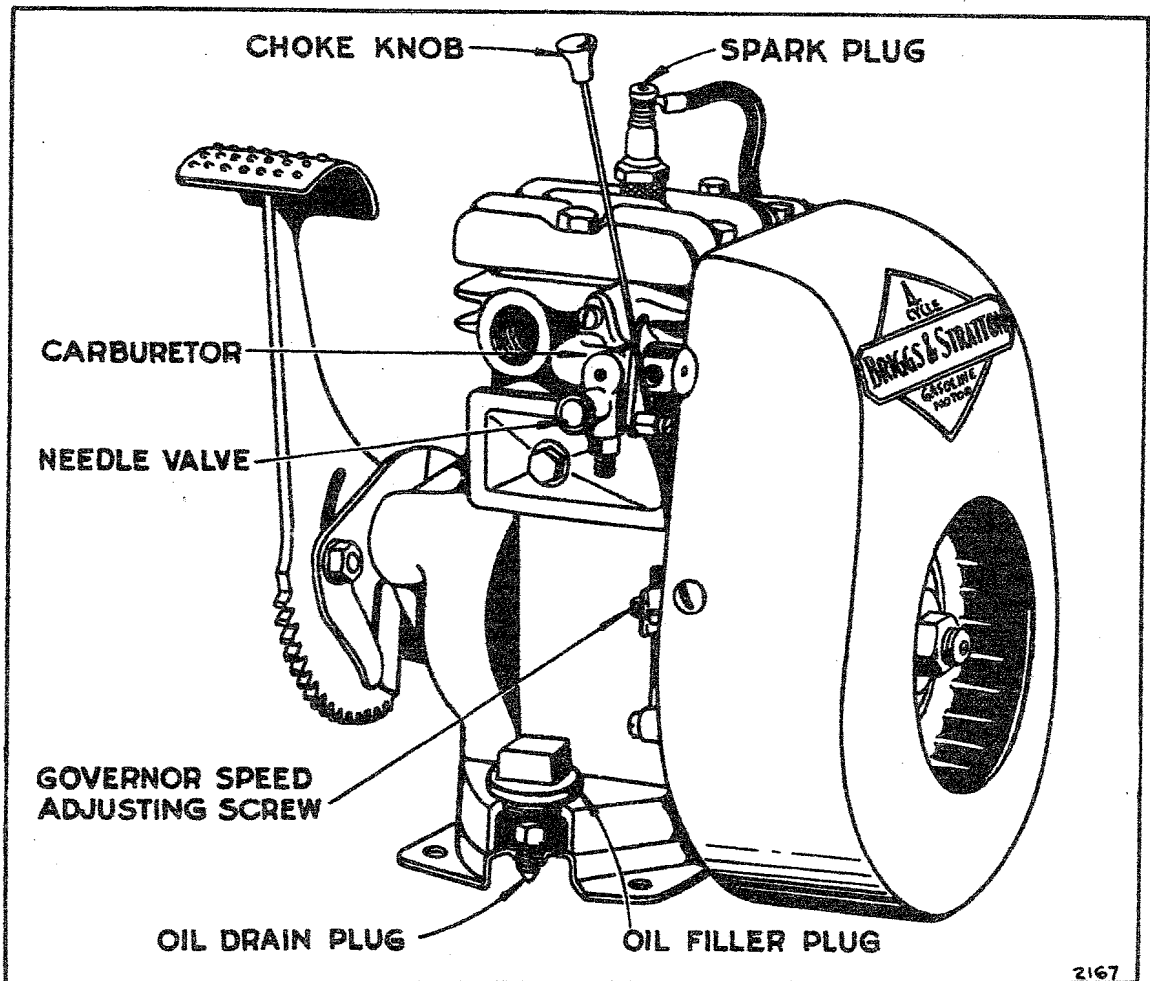

# Servicing Reference Chart

## MOTOR FAILS TO START

	Paragraph
Out of Gasoline.....	1-16
Out of Oil.....	1-13
Dirt or Gum in Fuel System.....	16 to 19
Incorrect Use of Choke.....	20
Carburetor Out of Adjustment.....	22 to 25
Spark Plug Dirty.....	29-30
Ignition Cable Grounded.....	31
Magneto.....	32 to 40
Poor Compression.....	41 to 49
Starter Clutch.....	59

## MOTOR STOPS

Out of Gasoline.....	1-16
Out of Oil.....	1-13
Dirt or Gum in Fuel System.....	16 to 19
Motor Overheated.....	13-53-57
Motor Overloaded.....	57

## MOTOR OVERHEATS

	Paragraph
Out of Oil.....	1-13
Oil Needs Changing.....	14-15
Oil Too Heavy.....	14-15
Carburetor Out of Adjustment.....	22 to 25
Poor Spark.....	28 to 40
Carbon.....	53
Overloaded.....	55-57

## MOTOR LACKS POWER

Lack of Oil.....	1-13
Add or Change Oil.....	13 to 15
Carburetor Out of Adjustment.....	22 to 25
Motor Not Up to Speed.....	26-27
Poor Spark.....	28 to 40
Poor Compression.....	41 to 49
Carbon.....	53
Muffler or Exhaust Hose Fitting Clogged.....	55
Exhaust Tubing.....	56
Overloaded.....	55-57

# Instructions for Adjustment and Repair

	Paragraph
Operating Requirements.....	8
How a 4-Cycle Motor Works.....	10
Keep the Motor Clean.....	11
Use the Right Kind of Oil.....	12
Add Oil Regularly.....	13
Change Oil Frequently.....	14
Use Clean Gasoline.....	16
Avoid Gummy Gasoline.....	17
To Clean the Fuel Lines.....	19
Correct Use of the Choke.....	20
To Prime the Motor.....	21
To Adjust the Carburetor.....	22
To Remove and Replace Carburetor.....	24
To Remove and Replace Carburetor Throttle Governor—Correct Motor Speed.....	25
.....	26
The Ignition System.....	28
To Check for Spark.....	29
Spark Plug Adjustment.....	30
Ignition Cable.....	31
To Remove and Replace Flywheel.....	32

	Paragraph
To Remove and Replace Magneto.....	34
Magneto Timing.....	35
To Adjust and Clean Contact Points.....	36
To Replace Condenser.....	37
To Replace and Adjust Armature.....	39
Cylinder Head.....	41
Compression.....	42
Valve Adjustment.....	43
Piston.....	47
Piston Rings.....	49
Piston Pin.....	50
Connecting Rod.....	51
Oil Leaks.....	52
Carbon.....	53
Air Cleaner.....	54
Muffler or Exhaust Hose Fitting.....	55
Exhaust Tubing.....	56
Overload.....	57
Starter Pedal Adjustment.....	58
Starter Clutch.....	59
Parts.....	60

**8. OPERATING REQUIREMENTS.** A gasoline motor to operate properly must have all parts in correct adjustment to provide good ignition, carburetion, compression and cooling. And of equal importance, the oil and gasoline used must be **clean** and of the recommended grades. The following instructions fully explain the simple adjustments and offer operating recommendations that will

assure you complete satisfaction. We urge you to carefully observe them.

**9.** The reliability, economy and ease of starting which characterize this motor are due in part to the fact that it is of the 4-stroke cycle design commonly called "4-cycle," the same design used in all automotive motors. As the name indicates there are four strokes to one complete power cycle.

10. **HOW A 4-CYCLE MOTOR OPERATES.** On the **intake stroke** the piston goes down, producing a vacuum in the cylinder, thereby drawing fuel up through the carburetor so that the space above the piston becomes filled with combustible gas. During this stroke the intake valve is open. Next the piston comes up on the **compression stroke** with both valves closed. At the top of the compression stroke a spark occurs at the spark plug, firing the highly compressed gas. This produces an explosion above the piston which forces it down on the **power stroke**. Both valves are closed. On the next upstroke of the piston, called the **exhaust stroke**, the exhaust valve is open, and the burned gases driven out. See plate No. 2.

The 4-Stroke Cycle  
Plate No. 2

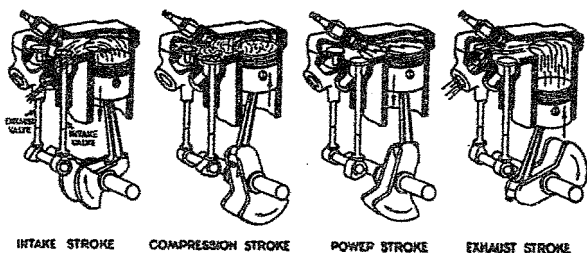

11. **KEEP THE MOTOR CLEAN.** It will pay you to keep your motor clean both inside and outside. See that no dirt or water enters motor when filling with oil or gasoline. As a precautionary measure always wipe off the gasoline cap and oil filler plug, as well as around them before refilling. Dirt in the motor or gasoline tank will cause trouble and even serious damage.

12. **USE THE RIGHT KIND OF OIL.** Correct lubrication is important. We recommend the use of MOBIL OIL "ARCTIC" or other high grade oil with similar characteristics having a low carbon residue and a body not heavier than S. A. E. No. 20. A heavier oil which might be satisfactory in a tractor or for lubricating farm machinery must NOT be used. Do not mix oil with the gasoline. This 4-cycle motor is provided with an efficient splash lubrication system. A dipper on the connecting rod dips into and throws oil to all moving parts. There are no external parts which require separate oiling.

13. **ADD OIL REGULARLY.** A motor which is run without oil will be ruined within a few minutes. To avoid the possibility of such an occurrence and the resulting expense, always fill the oil reservoir at the blue plug to the top of the filler plug opening after each five hours of motor operation. Capacity of oil reservoir is approximately  $\frac{1}{3}$  pint.

14. **CHANGE OIL FREQUENTLY.** After every twenty-five hours of motor operation, the oil should be completely drained from the crankcase. Do not remove motor from its mounting base. Remove blue oil filler plug and use special wrench furnished with your motor to unscrew oil drain plug located in base plate and remove it through oil filler opening. The old oil will drain straight down through this hole in the base plate into the pan or other receptacle you use. See plate No. 3. We do not recommend flushing out with kerosene. Replace the drain plug, refill with fresh oil and replace the blue filler plug.

15. In the normal running of any motor, small particles of metal from the cylinder walls, pistons and bearings will gradually work into the oil. Dust particles from the air also get into the oil.

Sludge, a gummy mass, forms which clogs up the oil passages. If the oil is not changed regularly, these foreign particles cause increased friction and a grinding action which shortens the life of the motor. Fresh oil also assists in cooling, for old oil gradually becomes thick and loses its cooling as well as its lubricating qualities.

How to Drain Oil  
Plate No. 3

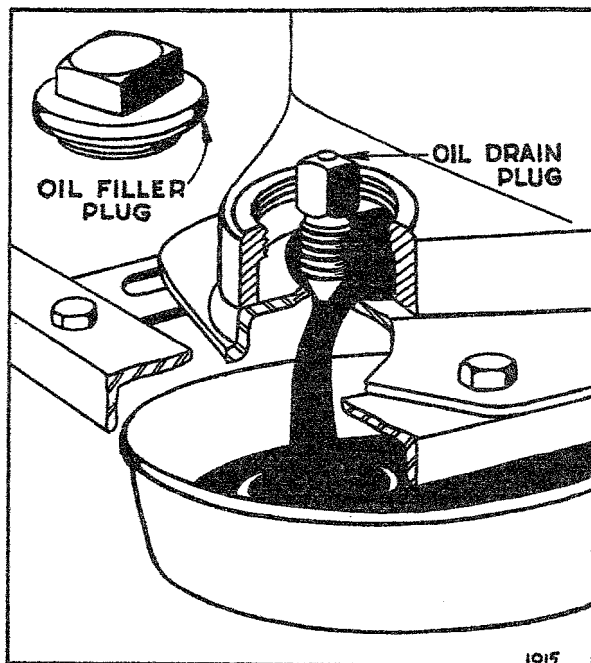

16. **USE CLEAN GASOLINE.** A good, clean, third grade, fresh gasoline is recommended. Too high test gasoline may form vapor-lock in gas line when motor gets hot. This interrupts the flow of gasoline and causes motor to stop. Be sure that the small vent hole in the gasoline tank cap is not clogged up, for air must enter the tank to allow the gasoline to flow to the carburetor. Test by blowing through top of cap.

17. **AVOID GUMMY GASOLINE.** If you experience trouble with a gummy, sticky substance with a peculiar sharp obnoxious smell, change to another brand of gasoline. This gum comes from the gasoline and clogs carburetor, gas line, gasoline tank, check valve, etc. You can check your gasoline by evaporating a half pint in an open dish. If a quantity of gum remains, try another kind that is clean and fresh.

18. You can avoid most trouble from gum if you will keep the tank full when you are not using the motor. If you use it only occasionally, drain tank completely and refill when motor is used again. The reason for this is that evaporation of stale gasoline causes most gum deposits.

19. **TO CLEAN THE FUEL LINES.** Disconnect the gasoline line at the carburetor and also at the gas tank. Blow through the gas line to clear. Remove the gas tank feed pipe which is screwed into the gas tank proper. At its base you will find a screen which may be clogged. To determine whether this pipe itself is clear, blow through the pipe from the screen end. There is a check ball in the base of this pipe which must be free. See plate No. 4. Check ball must close air passage when blowing through opposite end of pipe. When replacing gas pipe in tank,

be sure to place gasket between gas tank and gas pipe nut. **IMPORTANT:** If you find a gummy varnish-like substance, alcohol or acetone will dissolve it. See paragraphs 17 and 18.

**Gas Pipe  
Plate No. 4**

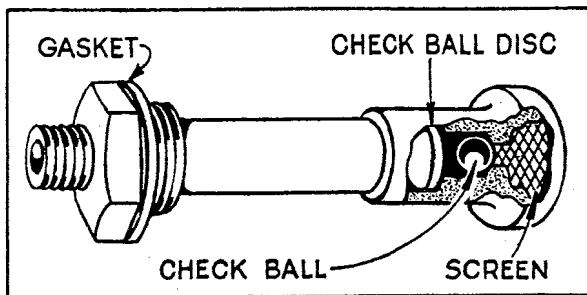

**20. CORRECT USE OF THE CHOKE.** The correct carburetor setting (see paragraph 23) gives the motor the best mixture to run on when it is hot. For starting, it is necessary to choke the carburetor to get a rich mixture, because cold gasoline does not vaporize readily. A warm or hot motor requires very little choking. Until you become familiar with your motor, however, you may make the mistake of not choking the carburetor enough or you may choke it too much. If motor fails to start after cranking three or four times with the choke up, or closed, try cranking two or three times with the choke part way down and then all the way down, or open. Use motor choke the same as you use an automobile choke.

**21. TO PRIME THE MOTOR.** The motor may fail to start for the reason that either the carburetor is incorrectly adjusted or dirty, or the fuel line or gas pipe check valve in the gasoline tank is dirty or clogged, or you are out of gasoline. To determine the cause, prime the motor by removing the spark plug and pour a half teaspoonful of gasoline into the spark plug opening. Replace the spark plug and crank the motor. If it fires for three or four revolutions and stops, the difficulty is definitely in the fuel system. See paragraphs 19, 22 to 25. If motor will not fire at all, check the ignition system, see paragraphs 28 to 40; also compression, paragraphs 42 to 49.

**22. TO ADJUST THE CARBURETOR.** The carburetor on the Model "WMB" motor is of the suction type. The gasoline supply is regulated by a needle valve. The throttle is automatically controlled by the governor, see paragraph 26.

**23.** To adjust the carburetor, completely close needle valve by turning to right or clock-wise as far as possible. Do not screw up too tight or use force when closing needle valve, or the seat, or taper of needle valve may be damaged. From closed position, open needle valve one complete turn. After the motor has been started and warmed up with the choke wide open, make final adjustment by turning the needle valve to the point at which motor operates most smoothly with full load. This setting will also take care of starting with use of the choke. When starting cold motor, if it is necessary to keep choke partially closed several minutes before motor runs smoothly, carburetor setting is too lean and needle valve should be opened a notch or two—turn to left. If carburetor throttle acts sluggish or motor does not govern smoothly, it is usually caused by a dirty or gummy throttle. See paragraph 25. For governor adjustments see paragraph 26.

**24. TO REMOVE AND REPLACE CARBURETOR.** Disconnect gasoline line from carburetor. Remove blower case. Remove valve

cover plate. Loosen two carburetor mounting screws. Carefully remove carburetor and, without stretching governor spring, unhook its lower end. Do not remove governor spring or link from throttle arm. Then unhook carburetor from the throttle link. To replace, reverse the operations as performed above. **CAUTION:** Be sure to replace the carburetor gasket. In replacing the throttle link be sure that the upper or hooked end is away from the carburetor. See plate No. 5. The throttle link must operate freely in the governor arm blade and the carburetor throttle arm.

**Carburetor and Governor Hook-up  
Plate No. 5**

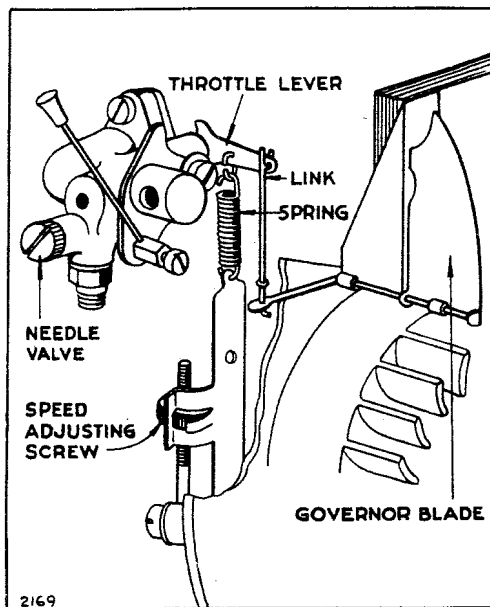

**25. TO REMOVE AND REPLACE CARBURETOR THROTTLE.** To clean the carburetor throttle, remove the carburetor as explained in the previous paragraph. To remove the throttle, loosen the set screw which holds the choke valve and carburetor throttle in place. The throttle is easily removed with the fingers. The throttle is part of an assembly consisting of the throttle, sleeve, throttle lever and governor spring. Clean in alcohol or acetone. Do not scrape. To reassemble, replace choke valve, insert throttle assembly into the carburetor body as far as it will go, lining up holes in sleeve with locating hole in body and with throttle stop between forked points of throttle lever. Push the sleeve of throttle in place by inserting a small tool between throttle lever and sleeve, so that set screw holes line up. Tighten set screw, being sure that choke valve friction spring, plain washer and lockwasher are in proper place.

**Carburetor Throttle  
Plate No. 6**

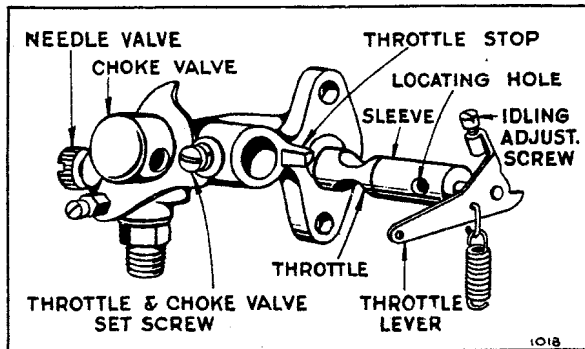

**26. GOVERNOR—CORRECT MOTOR SPEED.** The speed of your Model "WMB" motor is automatically maintained under varying loads by a pneumatic governor. It is operated by the air current blown by the flywheel.

**27.** The governor was carefully adjusted at the factory to maintain normal speed under load. Do not re-adjust unless absolutely necessary. A sliding speed adjuster is located beneath carburetor. Moving the slide down increases motor speed, up decreases motor speed. Tap lightly to adjust. See plate No. 5. Recommended speed is from 2200 to 2400 R.P.M. The idling speed is set at 1100 R.P.M. On washing machine application, adjust motor speed to operate washing machine agitator at speed recommended by the manufacturer of your washer. To remove or replace governor parts, see paragraph 24.

**28. THE IGNITION SYSTEM.** The spark is produced by a high tension magneto consisting of armature, condenser, contact points and rotating magnets cast in the flywheel. This is a simple self-contained system which is very reliable. It also does away with batteries. The ignition current is sent into the motor cylinder through the ignition cable and spark plug. The magneto itself as well as the cable and spark plug must all be in proper condition and adjustment to insure a good hot spark.

**29. TO CHECK FOR SPARK.** To prove that a satisfactory spark is being delivered by the magneto, remove the ignition cable from the plug. Hold ignition cable terminal about  $\frac{1}{8}$ " from any metal part of the cylinder head (keep hand on insulated part of the cable to avoid a shock). Turn motor with starter, and if the spark jumps this gap the entire ignition system, with the exception of the spark plug, is O. K. See plate No. 7. (To check spark plug see paragraph 30.) If no spark, check cable, see paragraph 31, and refer to magneto adjustments paragraphs 32 to 40.

Checking Spark  
Plate No. 7

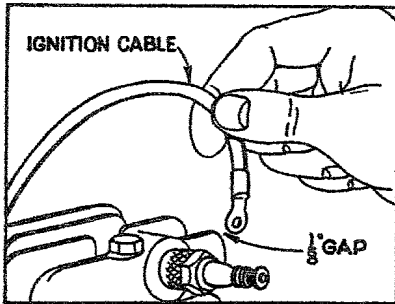

Spark Plug  
Plate No. 8

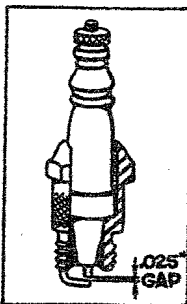

**30. SPARK PLUG ADJUSTMENT.** Spark plugs should be cleaned occasionally and points reset to .025". Points burn away in service. The porcelain is to prevent the spark from jumping anywhere except at the gap, and if cracked or broken it will prevent plug firing. Water on the outside of the spark plug may permit the high voltage current to leak over the surface of the porcelain. Dirt or carbon on it will do the same thing. Always keep a new plug on hand. We recommend the use of Champion No. J8 or its exact equivalent.

**31. IGNITION CABLE.** Insulation must not be broken or soaked with oil or water or grounded in any way where it touches the motor, or it will interfere with good ignition. To check cable all the way to magneto it is necessary to remove blower case. Ignition cable should be securely wound to the secondary terminal loop of the coil. See plate No. 12.

**32. TO REMOVE AND REPLACE FLYWHEEL.** The flywheel is securely mounted to the crankshaft by means of a taper fit, a key, a LEFT hand nut and a spring washer. Remove the blower housing. Bolt or clamp motor to work bench. Place a wood block

under flywheel fin on right side of flywheel or a small rod between fins, to hold it rigid and prevent turning as you loosen nut. See plate No. 9. Use large wrench, 10-inch or bigger. To start nut, to the RIGHT, tap end of wrench handle lightly with hammer. Tap carefully or a broken fin may result which will throw flywheel out of balance. After nut is removed, loosen flywheel by placing the wood block against end of crankshaft and striking with a hammer. Pull off flywheel.

Removing Flywheel  
Plate No. 9

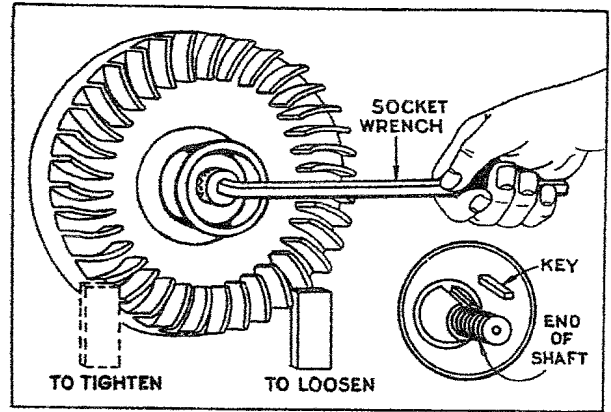

**33.** To reassemble, locate flywheel on crankshaft with key and install spring washer with the hollow or concave side next to the flywheel. Turn nut to LEFT until tight. Then use block under fin on left side of flywheel or rod between fins to hold flywheel rigid and draw nut up very tight by tapping wrench handle with hammer.

**34. TO REMOVE AND REPLACE MAGNETO ASSEMBLY.** After removing the flywheel as explained in paragraph 32, remove cover plate from the valve chamber, remove carburetor, see paragraph 24, unhook governor spring, detach the ignition cable from spark plug, and unscrew the four magneto plate mounting screws. To replace use same gasket between the plate and crankcase, or, if damaged, a new gasket, see part numbers 67307, 67597, 67607, of proper thickness to get correct end play of .002" to .008" between magneto bearing and crankshaft thrust faces, as shown in plate No. 10. Use lockwashers under mounting screws.

Correct End Play  
Plate No. 10

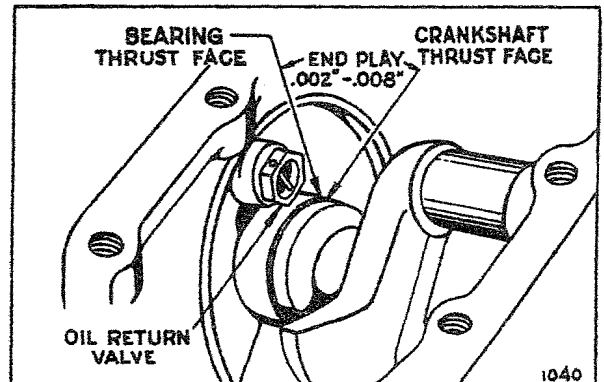

**35.** Magneto assembly is always correctly timed with the motor when the flywheel is assembled to the tapered crankshaft with a key and securely held in place with LEFT hand threaded nut.

Do not attempt to change the timing by relocating any parts or filing crankshaft timing flat. Always use soft key part No. 61760 — if steel key is used and flywheel becomes loose, it will damage the keyway in the crankshaft.

**36. TO ADJUST AND CLEAN CONTACT POINTS.** Remove blower housing and flywheel. Turn crankshaft by hand to see if contact points open and close properly. Points must be clean and line up squarely to make good electrical contact. Do not file contact points — use fine sand paper or fine grit hone to clean points. Adjust gap to .020" by loosening the adjusting lock screw and moving contact point bracket up or down. When proper gap is obtained tighten lock screw securely. If either or both points become badly pitted or burned and need replacement, always order complete assembly Part No. 29667.

**37. TO REPLACE CONDENSER.** A leaky or weak condenser may cause the motor to start hard, to sputter or misfire under load. If motor misfires after checking gasoline line, carburetor, spark plug, cable and contact points, install a new condenser. Both the condenser lead and armature lead must be soldered to brass arm, see plate No. 11. Be sure to push condenser lead down between condenser and hub of magneto plate so it cannot rub against flywheel.

**38.** If after new condenser has been installed the ignition system does not deliver a satisfactory spark, we recommend sending the complete magneto and the flywheel to the nearest Briggs & Stratton Central Service Distributor, listed on page 15, for proper adjustment.

**Contact Points and Condenser  
Plate No. 11**

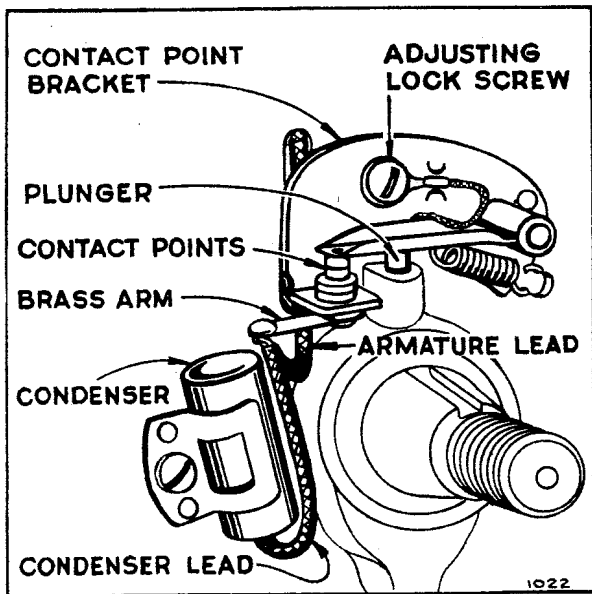

**39. TO REPLACE AND ADJUST ARMATURE.** Remove primary armature lead wire of coil from brass arm on contact bracket. Remove high tension ignition cable from secondary terminal loop in coil. Unscrew four armature mounting screws. After installing new armature be sure that condenser lead wire and armature lead wire from coil are soldered to brass arm on contact bracket. See plates Nos. 11 and 12. Replace mounting screws inserting loop of ground wires under screw and draw screws up tight.

**40.** Air gap of .008" to .012" must be maintained between armature core ends and flywheel. Gap must only be sufficient to prevent rubbing but not over .012", or poor ignition will result. To adjust gap to proper clearance, loosen the four armature mounting screws, slide armature assembly up and place correct feeler

gauge or 3 thicknesses of newspaper between rim of flywheel and armature core ends. Lower armature assembly until core ends rest on gauge or paper and tighten mounting screws securely. See plate No. 12.

**Complete Magneto Assembly  
Plate No. 12**

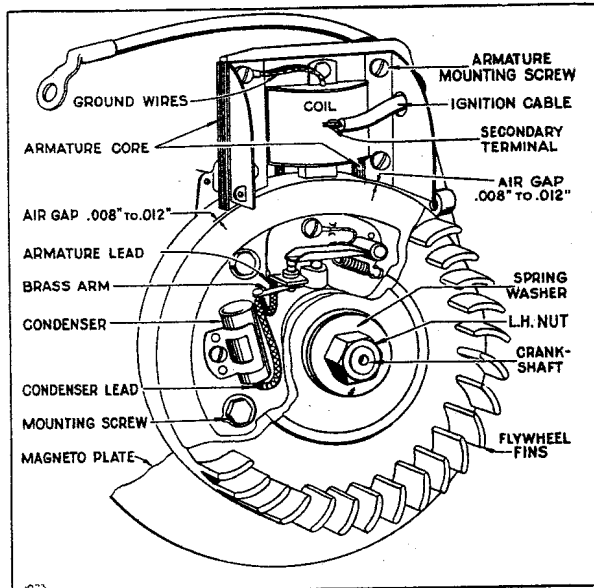

**41. CYLINDER HEAD.** The cylinder head is held on with six cap screws. When the cylinder head has been removed for the purpose of cleaning carbon or grinding valves, care should be used in replacing it. Use a new gasket if possible. Otherwise, clean the old one and coat both sides with cup grease. We do not recommend the use of shellac on cylinder head gaskets. Tighten each cap screw a little at a time so that the cylinder head is pulled down evenly. Screws need be only moderately tight.

**42. COMPRESSION.** Proper compression is obtained when valves seat properly, gaskets do not leak and piston and rings are properly fitted. When tuning up a motor, it is always well to check compression. This is done by turning the motor over slowly. If a point of resistance is offered every other revolution, compression should be satisfactory. If motor turns over without compression resistance for a full cycle, a worn piston, piston rings, cylinder wall, or leaky valves or leaky gaskets are present. See that spark plug has a gasket under it and is drawn up tight. Also check cylinder head gasket and tighten cylinder head bolts.

**43. VALVE ADJUSTMENT.** To check valve clearance remove valve cover plate on cylinder below carburetor. The correct clearance on the exhaust valve is .008" and on the intake valve .006" when the motor is cold. Tappet clearance is adjusted by grinding required amount from the end of valve stem. End of stem must be square with the stem proper.

**44.** To remove the valves, remove cylinder head and, if not dismantled, drain oil from crankcase. Invert cylinder. Compress the valve spring with a screw driver and pull out valve retainer pin with long nose pliers. Tilt cylinder back far enough to allow valve to drop, permitting its stem to clear the spring. Pry the spring out with screw driver. To replace, reverse the operations as performed above.

**45.** To reset valves, grind in same manner as automobile valves. If valves stick they may be coated with gum or carbon. To remove gum use alcohol or acetone. Clean valve stems thoroughly with wire brush or emery cloth. Also scrape all carbon from valve ports.

46. The timing of the valves is taken care of by the meshing of the cam gear with the gear on the crankshaft. These gears are properly meshed when the mark on the cam shaft gear is in line with the mark on the crankshaft collar.

Valve Timing — Plate No. 13

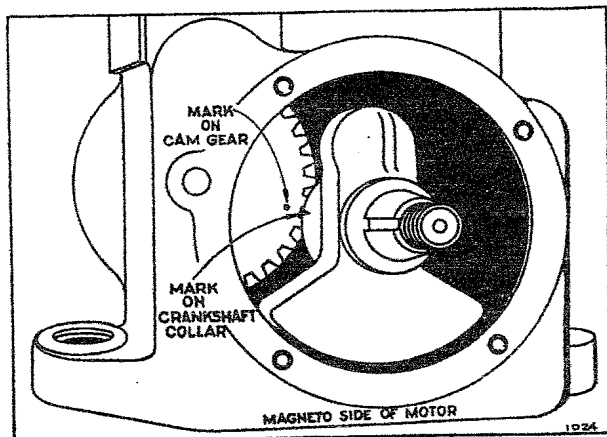

47. **PISTON.** The piston in the Model "WMB" motor is made of a special aluminum alloy which is very light in weight. The clearance between the piston and cylinder wall is .005" to .0065". This clearance is to compensate for the expansion of aluminum when hot. When piston is removed be sure to clean carbon from head of piston and ring grooves. If piston is out of round or scored it should be replaced.

48. When fitting a new piston in the motor, assemble it with the free side pin hole (indicated with an "X" on boss) toward the magneto side. If an oversize piston is necessary, we recommend that reboring of cylinder be done by an Authorized Central Service Distributor or the factory.

49. **PISTON RINGS.** The piston rings when fitted in the cylinder should have a gap from .007" to .015". The rings should be fitted in the cylinder below the piston ring travel. Before assembling new rings to piston be sure that piston ring grooves are thoroughly cleaned, and rings fit free in the grooves.

50. **PISTON PIN.** The piston pin is a free fit in one side of the piston and a tight fit in the other. To remove this pin without special equipment, it is advisable to heat the piston in boiling water which causes the aluminum to expand. Cut a wooden pin a little smaller than the size of the piston pin and use this and a hammer to drive the pin out. Drive the pin out through the free fit hole. This hole is toward the magneto side and is indicated with an "X" on the pin hole boss. You should, of course, drive the pin out while the piston is still hot. To easily replace the pin, the piston should be heated.

Connecting Rod — Plate No. 14

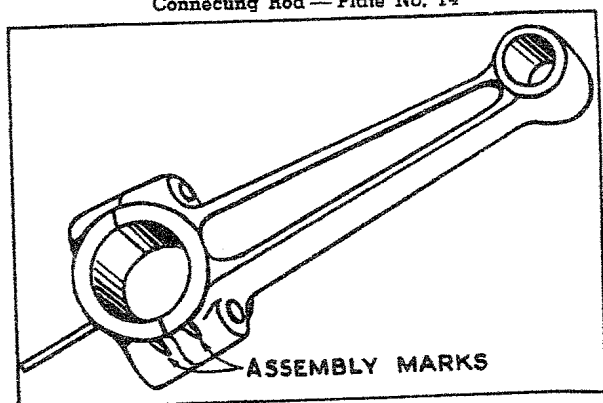

51. **CONNECTING ROD.** The connecting rod is also made of a special aluminum alloy which combines strength with light weight. When assembling connecting rod to crankshaft, the assembly marks on the lower bearing must be toward the magneto side. See plate No. 14. The assembly marks on cap and rod must be on the same side.

52. **OIL LEAKS.** If oil leaks from either end of crankshaft, remove base plate from motor. Oil return valves are screwed into crank case and magneto back plate at base of main bearings. Remove oil return valve and clean or flush with gasoline and blow out any dirt lodged under the small disc. See plate No. 10.

53. **CARBON.** Excessive carbon is caused by improper grade of oil — too much oil, usually the result of piston rings not seating properly or sticking — carburetor set too rich — or long service. An unusual amount of carbon is noticeable by motor knocking or loss of power. Occasionally remove carbon from piston head, cylinder head and top of cylinder bore.

54. **AIR CLEANER.** If an air cleaner is used it should be occasionally removed and cleaned by washing in kerosene, then dipped in oil to make it efficient in catching dust. Test to see if it is clogged by noting if motor performs better with it off. If clogged it should be replaced.

55. **MUFFLER OR EXHAUST HOSE FITTING.** After long periods of service it is possible that the muffler, exhaust hose fitting, or the exhaust tubing will become clogged and reduce motor power. To check the muffler run water into the open end. If full streams of water come out of the small holes at the opposite end it is O. K. If not, it should be replaced. Exhaust hose fitting is removed by unscrewing nut — holes should be fully open.

56. **EXHAUST TUBING INSTALLATION.** A certain amount of water forms inside of the exhaust tube after it cools off due to condensation. After motor is stopped, place exhaust tube so that water from condensation cannot drain into exhaust part of motor to corrode the mechanical parts and eventually result in trouble. If exhaust pipe is too long, or clogged, back pressure will reduce motor power. To prevent poisonous exhaust gases escaping, when motor is to operate indoors, follow this correct assembly procedure: Place the exhaust fitting so that the outlet is directly over the cylinder head. Screw the locknut in place and tighten securely with a  $\frac{1}{2}$ " open-end or crescent wrench. Slip the exhaust tube over the fitting and turn tubing to the right until its end fits tight against the shoulder of the exhaust fitting. See plate No. 15.

Plate No. 15

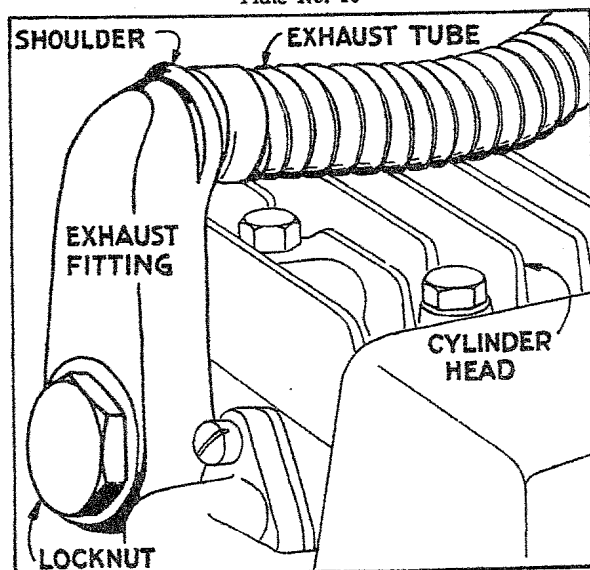



**57. OVERLOAD.** Always be sure that the machine the motor is operating is well lubricated and running freely. If it is not, it may cause the motor to become overloaded resulting in it overheating, losing power, or even stopping entirely.

**58. STARTER PEDAL ADJUSTMENT.** The starter pedal is made in two parts, the pedal proper and pedal stop, held together with the adjusting bolt. To adjust, loosen the bolt and set pedal to desired position. Adjust the pedal to get the longest possible stroke without striking any part of the machine. The first tooth on the starter sector must clear the teeth of the starter pinion. Should the starter pedal return spring loosen or lose its tension, loosen the bolt which holds the return spring cup. Turn the cup to the left until there is just enough tension to return the starter pedal back to the normal position after depressing it, and tighten the bolt. Too much tension may cause spring to break. Be sure the spring is in the proper position with the long end below the pedal adjusting bolt and the hooked end in the slot of the cup.

**Starter Pedal Adjustment  
Plate No. 16**

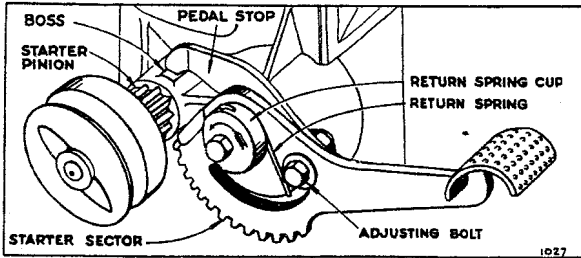

**59. STARTER CLUTCH.** If the starter clutch slips or fails to turn the motor, when stepping on the starter pedal, it is probably caused by one of the following reasons:

- Loose set screw.
- Worn clutch housing.
- Worn or broken pinion.

First tighten the set screw to be sure clutch is tight on the crankshaft. Use  $\frac{5}{16}$ " Allen hexagon set-screw wrench. If the clutch still slips, loosen set screw and remove clutch from the shaft. Pry out the snap spring with a sharp tool, holding the clutch in the position shown in plate No. 17, as a caution against the spring jumping out. Check the parts carefully for wear or damage and replace those necessary. To reassemble, replace the parts in the same order, and slip the spring back in place. Replace pulley clutch on shaft with the set screw hole lined up with recess in crankshaft extension. Securely tighten set screw.

**Starter Clutch  
Plate No. 17**

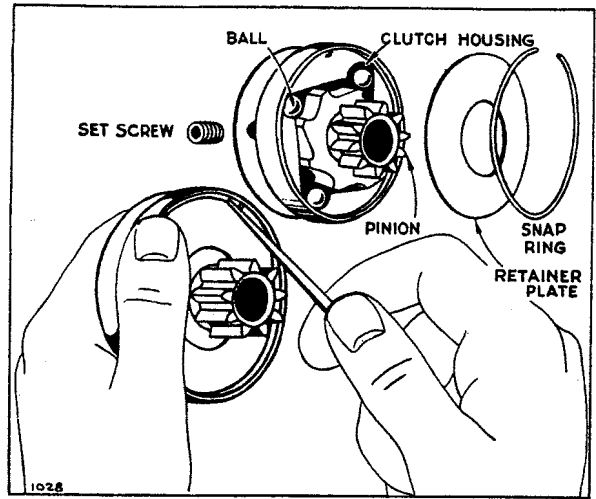

**60. PARTS.** All parts should be ordered from your dealer or the nearest Authorized Briggs & Stratton Service Distributor, listed on page 15.

## Repair Parts

	Paragraph
Always Give Type, Model and Serial Number . . . . .	62
How to Make Out Parts Order . . . . .	64
Prices . . . . .	68

	Page
Parts List . . . . .	11-13
Parts Illustrations . . . . .	14

**61.** To assure continued satisfactory performance, do not attempt to use substitute repair parts when overhauling or repairing the Briggs & Stratton Motor. Insist that all repair parts be original Briggs & Stratton parts.

**62. ALWAYS GIVE TYPE, MODEL AND SERIAL NUMBERS.** Briggs & Stratton motors are identified by a type number, model letter and a serial number. This information is stamped on a metal plate attached to the blower housing.

**63.** When writing to the factory or to a Central Service Distributor for service information, or when ordering new parts, be sure to specify the type number, the model, and the serial number of the motor to be serviced. This will assure prompt and efficient service without unnecessary correspondence.

**64. HOW TO MAKE OUT PARTS ORDERS.** Print your name and address plainly and correctly. Do not abbreviate name of town or state. Specify on the order how shipment to you is to be made. This will assist in giving prompt and efficient service.

**65.** Give part number and name of parts wanted. (Do not use number cast on parts.) You will find the part number, names and prices on pages 11 to 13, and parts illustrations on page 14.

**66.** After you have made out order, check back to see that you have followed all instructions and have accurately listed what you want.

**67.** Shipments will be made C.O.D. or send remittance with order to cover parts and add what you think will be sufficient for postage. Send postal or express money order, bank draft or certified check for this amount. Do not send currency in a letter. It is not safe.

**68. PRICES.** All prices in this book are subject to change without notice. In case of change in prices, orders will be filled at current prices. All prices shown are F.O.B. Factory at Milwaukee, Wis., or nearest Authorized Central Service Distributor. Prices higher in Canada.

# Model "WMB" Parts List

PART NUMBER	NAME	PRICE EACH	PART NUMBER	NAME	PRICE EACH
7T17	Lockwasher .....	3 for \$ 0.05	29779	Piston Assembly — .020" Oversize.....	2.85
590E	Fibre Washer .....	3 for .05		Includes:	
19005	Choke Rod .....	.15		26026 Pin Lock	
23068	Speed Adjusting Nut.....	.10		29782 Piston	
23069	Speed Adjusting Screw.....	.05		61769 Compression Ring	
23131	Carrying Handle Spacer.....	.10		61772 Oil Ring	
26018	Contact Bracket Spring .....	.05	29780	Piston Assembly — .030" Oversize.....	2.85
26021	Valve Spring .....	.05		Includes:	
26025	Pedal Return Spring .....	.10		26026 Pin Lock	
26026	Piston Pin Lock.....	3 for .05		29783 Piston	
26032	Clutch Retainer Spring .....	.05		61770 Compression Ring	
26033	Governor Spring .....	.10		61773 Oil Ring	
26121	Crankshaft .....	4.50	29781	Piston — .010" Oversize .....	2.00
	NOTE: No. 26163 used on type No. 95506.		29782	Piston — .020" Oversize .....	2.00
26163	Crankshaft .....	5.50	29783	Piston — .030" Oversize .....	2.00
29243	Gas Line — 10" long.....	.25	29786	Starter Sector .....	2.00
29411	Gas Line — 13" long.....	.25	29788	Starter Pedal Assembly — right hand offset.....	3.25
29544	Gas Line — 27" long.....	.40	29796	Carburetor Body .....	.65
29658	Breather Tube .....	.40		NOTE: No. 29875 used on type No. 95506.	
29667	Contact Point Assembly .....	.75	29799	Throttle Lever .....	.65
	Includes:			NOTE: No. 29851 used on type No. 95506.	
	26018 Spring		29800	Carburetor Assembly .....	2.00
	29668 Arm			Includes:	
	29669 Bracket			29796 Body	
29668	Contact Breaker Arm.....	.20		29799 Throttle Lever	
29669	Contact Bracket .....	.50		29801 Choke Valve	
29671	Armature .....	3.00		62628 Retainer Washer	
29673	Magneto Plate with Bearing.....	2.75		62702 Choke Washer	
29675	Crankshaft Bearings .....	.25		63058 Connector	
29693	Spark Plug with Gasket.....	.65		63810 Needle Valve	
29704	Starter Pedal .....	2.25		63854 Screw	
29738	Cylinder Assembly .....	16.50		65787 Gasket	
	Includes:			67617 Packing	
	26021 Springs			90364 Lockwasher	
	29746 Cylinder			91253 Screw	
	61703 Cam Gear			61752 Screw	
	62534 Retainers			NOTE: No. 29821 used on type Nos. 95502, 95504, 95507.	
	63782 Intake Valve			No. 29828 used on type No. 95506.	
	63785 Cam Shaft		29801	Choke Valve .....	.25
	63787 Retainer Pin			NOTE: No. 61738 used on type No. 95506.	
	63788 Valve Tappet		29804	Starter Pedal Assembly — left hand offset.....	3.25
	63807 Exhaust Valve			NOTE: No. 99101 used on type No. 95496.	
	68122 Cam Shaft Plug			No. 99247 used on type No. 95486.	
	69817 Oil Valve		29806	Spark Plug Gasket.....	.05
	NOTE: No. 29849 used on type No. 95506.		29807	Muffler .....	.25
29739	Piston Assembly — Standard .....	2.35		NOTE: Exhaust tubing not included; furnished by washing machine manufacturer.	
	Includes:		29821	Carburetor Assembly .....	1.75
	26026 Pin Lock			Includes:	
	61732 Piston			62651 Washer	
	61756 Compression Ring			91199 Lockwasher	
	61757 Oil Ring			All other parts same as No. 29800.	
	NOTE: For Oversizes, see Nos. 29778 — .010", 29779 — .020", and 29780 — .030".		29325	Gasoline Tank .....	1.25
29741	Starter Clutch and Pulley.....	1.45		NOTE: No. 29859 used on type No. 95471.	
	Includes:		29826	Gasoline Line — 25½" long .....	.30
	26032 Spring		29828	Carburetor Assembly .....	2.25
	61700 Pulley			Includes:	
	62538 Retainer			29851 Throttle Lever	
	63770 Ball			29864 Connector	
	63794 Pinion			29875 Body	
	61758 Set Screw			61738 Choke Valve	
29743	Pulley — 2¾" Dia. ....	.50		62651 Washer	
	NOTE: No. 29913 — 1¼" Dia.			62702 Choke Washer	
29746	Cylinder with Bearing.....	12.00		63844 Needle Valve	
	NOTE: No. 29847 used on type No. 95506.			63854 Retainer Screw	
29767	Choke Rod — 11½" long.....	.15		65787 Gasket	
	NOTE: No. 19005 — 9½" long.			67617 Packing	
	No. 29869 — 11½" long.			91199 Lockwasher	
	No. 29876 — 15" long.		29830	Starter Pedal Assembly — Gooseneck.....	3.25
	No. 29909 — 9¼" long.			NOTE: No. 29880 used on type No. 60936.	
29778	Piston Assembly — .010" Oversize.....	2.85		NOTE: No. 99096 used on type Nos. 95352, 95491.	
	Includes:				
	26026 Pin Lock				
	29781 Piston				
	61768 Compression Ring				
	61771 Oil Ring				

<b>29833</b>	Cylinder Assembly .....	<b>14.25</b>	<b>61760</b>	Flywheel Key .....	<b>.10</b>
	Includes:		<b>61768</b>	Scrapers Compression Ring — .010" Oversize.....	<b>.25</b>
	26021 Valve Springs		<b>61769</b>	Scrapers Compression Ring — .020" Oversize.....	<b>.25</b>
	29746 Cylinder		<b>61770</b>	Scrapers Compression Ring — .030" Oversize.....	<b>.25</b>
	62534 Retainer		<b>61771</b>	Oil Ring — .010" Oversize.....	<b>.35</b>
	63782 Intake Valve		<b>61772</b>	Oil Ring — .020" Oversize.....	<b>.35</b>
	63787 Retainer Pin		<b>61773</b>	Oil Ring — .030" Oversize.....	<b>.35</b>
	63807 Exhaust Valve		<b>61781</b>	Pulley Clutch Housing.....	<b>.80</b>
	69817 Oil Return Valve		<b>61784</b>	Pulley Clutch Housing.....	<b>.80</b>
	NOTE: No. 29848 used on type No. 95506.		<b>61944</b>	Cylinder Head .....	<b>1.15</b>
<b>29835</b>	Magneto Flywheel .....	<b>6.00</b>	<b>62007</b>	Gas Tank Clips .....	<b>2 for .05</b>
<b>29836</b>	Starter Pedal — Gooseneck .....	<b>1.25</b>	<b>62498</b>	Blower Housing .....	<b>1.00</b>
	NOTE: No. 29879 used on type No. 60936.		<b>62534</b>	Valve Spring Retainer .....	<b>2 for .05</b>
	NOTE: No. 99082 used on type Nos. 95352, 95491.		<b>62536</b>	Return Spring Cup.....	<b>.05</b>
<b>29847</b>	Cylinder .....	<b>12.50</b>	<b>62538</b>	Clutch Retainer Plate.....	<b>.05</b>
<b>29848</b>	Cylinder Assembly .....	<b>14.75</b>	<b>62546</b>	Valve Cover .....	<b>.10</b>
<b>29849</b>	Cylinder Assembly .....	<b>17.00</b>	<b>62577</b>	Flywheel Washer .....	<b>.10</b>
<b>29851</b>	Throttle Lever .....	<b>.85</b>	<b>62599</b>	Spark Plug Wrench .....	<b>.10</b>
<b>29853</b>	Starter Clutch and Pulley.....	<b>1.65</b>	<b>62600</b>	Starter Pedal Stop .....	<b>.25</b>
	Includes:			NOTE: No. 99247 used on type No. 95486.	
	26032 Spring		<b>62628</b>	Choke Retainer Washer .....	<b>.05</b>
	61781 Housing			NOTE: No. 62651 used on No. 29821 Carburetor.	
	62538 Washer		<b>62631</b>	Rope Starter Pulley (without notch).....	<b>.45</b>
	63770 Ball		<b>62651</b>	Retainer Washer .....	<b>.05</b>
	63794 Pinion		<b>62693</b>	Rope Starter Pulley (notched).....	<b>.45</b>
	91758 Screw		<b>62702</b>	Choke Valve Washer .....	<b>.05</b>
<b>29858</b>	Gasoline Line — 21" long.....	<b>.30</b>	<b>62703</b>	Oil Spray Shield.....	<b>.10</b>
<b>29859</b>	Gasoline Tank .....	<b>1.25</b>	<b>62853</b>	Cylinder Shield .....	<b>.15</b>
<b>29864</b>	Gas Line Connector.....	<b>.25</b>	<b>62893</b>	Throttle Link .....	<b>.05</b>
<b>29865</b>	Gasoline Tank .....	<b>1.75</b>	<b>62896</b>	Speed Adjuster .....	<b>.05</b>
	Includes:		<b>62904</b>	Base Plate .....	<b>.40</b>
	29825 Gas Tank		<b>62943</b>	Carrying Handle .....	<b>.15</b>
	65294 Gas Pipe Washer		<b>63058</b>	Gas Line Connector.....	<b>.15</b>
	69221 Tank Cap			NOTE: No. 29864 used on type No. 95506.	
	69243 Gas Pipe		<b>63770</b>	Steel Clutch Ball.....	<b>2 for .05</b>
	NOTE: No. 29870 used on type No. 95471.		<b>63771</b>	Starter Pedal Bushing .....	<b>.10</b>
<b>29869</b>	Choke Rod — 11 $\frac{7}{8}$ " long.....	<b>.15</b>	<b>63772</b>	Oil Drain Plug.....	<b>.10</b>
<b>29870</b>	Gasoline Tank Assembly.....	<b>1.75</b>	<b>63773</b>	Piston Pin — Standard .....	<b>.20</b>
	Includes:			NOTE: No. 63816 — .005" Oversize.	
	29859 Gas Tank		<b>63782</b>	Intake Valve .....	<b>.45</b>
	65294 Gas Pipe Washer		<b>63783</b>	Exhaust Fitting Locknut.....	<b>.25</b>
	69221 Tank Cap		<b>63785</b>	Cam Shaft .....	<b>.30</b>
	69243 Gas Pipe		<b>63787</b>	Valve Spring Retainer Pin.....	<b>.05</b>
<b>29875</b>	Carburetor Body .....	<b>.70</b>	<b>63788</b>	Valve Tappet .....	<b>.25</b>
<b>29876</b>	Choke Rod — 15" long .....	<b>.15</b>	<b>63794</b>	Starter Pinion .....	<b>.65</b>
<b>29878</b>	Starter Rope .....	<b>.25</b>	<b>63807</b>	Exhaust Valve .....	<b>.75</b>
<b>29879</b>	Starter Pedal — Gooseneck .....	<b>1.25</b>	<b>63810</b>	Needle Valve .....	<b>.15</b>
<b>29880</b>	Starter Pedal Assembly — Gooseneck.....	<b>3.25</b>		NOTE: No. 63844 used on type No. 95506.	
<b>29881</b>	Starter Pedal — right hand offset.....	<b>1.25</b>	<b>63816</b>	Piston Pin — .005" Oversize.....	<b>.30</b>
<b>29882</b>	Starter Pedal — left hand offset .....	<b>1.25</b>	<b>63821</b>	$\frac{5}{16}$ " Allen Set Screw Wrench.....	<b>.20</b>
<b>29885</b>	Starter Clutch and Pulley.....	<b>1.45</b>	<b>63844</b>	Needle Valve .....	<b>.20</b>
	Includes:		<b>63854</b>	Throttle Set Screw .....	<b>.05</b>
	26032 Spring		<b>64409</b>	Gas Line — 23" long.....	<b>.30</b>
	61784 Pulley		<b>64419</b>	Gas Line — 9" long.....	<b>.25</b>
	62538 Washer		<b>65294</b>	Gas Pipe Washer.....	<b>.05</b>
	63770 Ball		<b>65534</b>	Filler Cap Gasket.....	<b>.05</b>
	63794 Pinion		<b>65704</b>	Contact Point Plunger .....	<b>.15</b>
	61758 Screw		<b>65725</b>	Armature Lead Insulator.....	<b>.05</b>
<b>29887</b>	Gasoline Line — 16" long.....	<b>.25</b>	<b>65787</b>	Fibre Connector Gasket .....	<b>2 for .05</b>
<b>29909</b>	Choke Rod — 9 $\frac{1}{4}$ " long .....	<b>.15</b>	<b>65905</b>	Magneto Ground Wire — 45" long.....	<b>.25</b>
<b>29913</b>	Drive Pulley — magneto side.....	<b>.50</b>	<b>65915</b>	Magneto Ground Wire — 49 $\frac{1}{2}$ " long.....	<b>.25</b>
<b>37346</b>	Rivet — $\frac{1}{8}$ x $\frac{1}{4}$ — Tubular .....	<b>3 for .05</b>	<b>66432</b>	Washer .....	<b>.05</b>
<b>38852</b>	Washer .....	<b>3 for .05</b>	<b>67307</b>	Magneto Plate Gasket.....	<b>.05</b>
<b>61700</b>	Pulley Clutch Housing.....	<b>.60</b>		NOTE: No. 67597 — .005" thick.	
<b>61703</b>	Cam Gear .....	<b>2.25</b>		No. 67607 — .009" thick.	
<b>61732</b>	Piston — Standard .....	<b>1.50</b>	<b>67527</b>	Valve Cover Gasket.....	<b>.05</b>
	NOTE: For Oversizes, see Nos. 29781 — .010",		<b>67537</b>	Cylinder Head Gasket.....	<b>.10</b>
	29782 — .020", and 29783 — .030".		<b>67547</b>	Base Gasket .....	<b>.05</b>
<b>61735</b>	Oil Filler Cap.....	<b>.15</b>	<b>67597</b>	Magneto Plate Gasket — .005" thick.....	<b>.05</b>
<b>61738</b>	Choke Valve .....	<b>.15</b>	<b>67607</b>	Magneto Plate Gasket — .009" thick.....	<b>.05</b>
<b>61755</b>	Exhaust Hose Fitting.....	<b>.50</b>	<b>67617</b>	Needle Valve Packing.....	<b>.05</b>
<b>61756</b>	Scrapers Compression Ring — Standard.....	<b>.25</b>	<b>68122</b>	Cam Shaft Plug.....	<b>.05</b>
	NOTE: For Oversizes, see Nos. 61768 — .010",		<b>68287</b>	Air Cleaner Gasket.....	<b>.10</b>
	61769 — .020", and 61770 — .030".		<b>68467</b>	Carburetor Mounting Gasket .....	<b>.05</b>
<b>61757</b>	Oil Ring — Standard .....	<b>.35</b>	<b>69221</b>	Gas Tank Cap.....	<b>.15</b>
	NOTE: For Oversizes, see Nos. 61771 — .010",				
	61772 — .020", and 61773 — .030".				

69243	Gas Pipe .....	.45
69326	Gas Line—22" long.....	.30
69335	Gasoline Line—19" long.....	.30
NOTE: For other lengths, specify:		
	No. 29243—10" long.....	
	No. 29411—13" long.....	
	No. 29544—27" long.....	
	No. 29826—25½" long.....	
	No. 29858—21" long.....	
	No. 29887—16" long.....	
	No. 64409—23" long.....	
	No. 64419—9¼" long.....	
	No. 69326—22" long.....	
	No. 69358—30" long.....	
	No. 99095—20" long.....	
69358	Gasoline Line—30" long.....	.50
69817	Oil Return Valve.....	.20
90066	Screw—8—32x¼" Rd. Hd.....	.05
90067	Screw—8—32x⅜" Rd. Hd.....	.05
90202	Screw—10—32x½" Fill. Hd.....	.05
90364	Lockwasher—1¼x¾x⅜".....	.05
90528	Screw—¼x28x¾" Hex. Hd.....	.05
90699	Lockwasher—¼x¾x⅜".....	.05
90950	Cap Screw.....	.05
91070	Lockwasher—No. 8 Shakeproof.....	.05
91195	Screw—¼—20x⅜" Rd. Hd.....	.05
91199	Lockwasher.....	.05
91203	Cylinder Head Screw.....	.10
91324	Washer—¼" Standard.....	.05
91359	Screw—10—32x¾" Fill. Hd.....	.05
91398	Screw—¼x28x½" Hex. Hd.....	.05
91688	Screw—8—32x1" Rd. Hd.....	.05

91707	Screw.....	.05
91708	Flywheel Nut.....	.05
91711	Cylinder Head Screw.....	.05
NOTE: No. 91203 used on type No. 95506.		
91741	Cap Screw.....	.05
91752	Screw—5—40x⅝" Fill. Hd.....	.05
91758	Set Screw—⅝—24x½" Holl. Hd.....	.10
91790	Air Cleaner Wing Nut.....	.05
91810	Muffler Elbow.....	.40
91811	Muffler Elbow Locknut.....	.05
91849	Connecting Rod Bolt.....	.05
99082	Starter Pedal.....	1.25
99095	Gas Line—20" long.....	.30
99096	Starter Pedal Assembly.....	3.25
99101	Starter Pedal Assembly.....	3.25
99106	Air Cleaner Elbow.....	.50
99193	Muffler.....	.75
99246	Starter Pedal Assembly.....	3.25
99247	Foot Lever Stop.....	.30
99277	Connecting Rod.....	1.00
99278	Governor Blade Assembly.....	.50
99282	Magneto Assembly.....	9.00
NOTE: No. 99304 used on type No. 95501. No. 99323 used on type No. 95466.		
99288	Ignition Cable.....	.15
99304	Magneto Assembly.....	9.25
NOTE: Same as No. 99282, with No. 65905—45" Ground Wire included.		
99323	Magneto Assembly.....	9.25
NOTE: Same as No. 99282, with No. 65915—49½" Ground Wire included.		

**IMPORTANT**  
**ALWAYS USE**  
**GOOD, CLEAN OIL**  
**S.A.E. No. 20**  
**ADD OIL FREQUENTLY**  
**CHANGE OIL REGULARLY**

**IMPORTANT**  
**ALWAYS USE**  
**GOOD, CLEAN OIL**  
**S.A.E. No. 20**  
**ADD OIL FREQUENTLY**  
**CHANGE OIL REGULARLY**

**THE GUARANTEE**—For One Year from purchase date. Briggs & Stratton Corporation will replace for the original purchaser, FREE OF CHARGE, any part or parts found, upon examination at our factory at Milwaukee, Wisconsin, or at any Authorized Central Service Distributor's place of business, to be defective under normal use and service, on account of defects in material or workmanship.

All transportation charges on part or parts submitted for replacement under this guarantee must be borne by purchaser.

**WHAT THIS GUARANTEE DOES NOT INCLUDE**—This guaranty does not cover the free replacement of parts inoperative because of wear occasioned by use. It does not cover the labor cost of replacing parts, neither is it effective if the motor has been the subject of misuse, negligence or accident, nor if it has been repaired or altered outside of our Milwaukee Factory or any Authorized Central Service Distributor in any way which, in our judgment, affects its condition or operation.

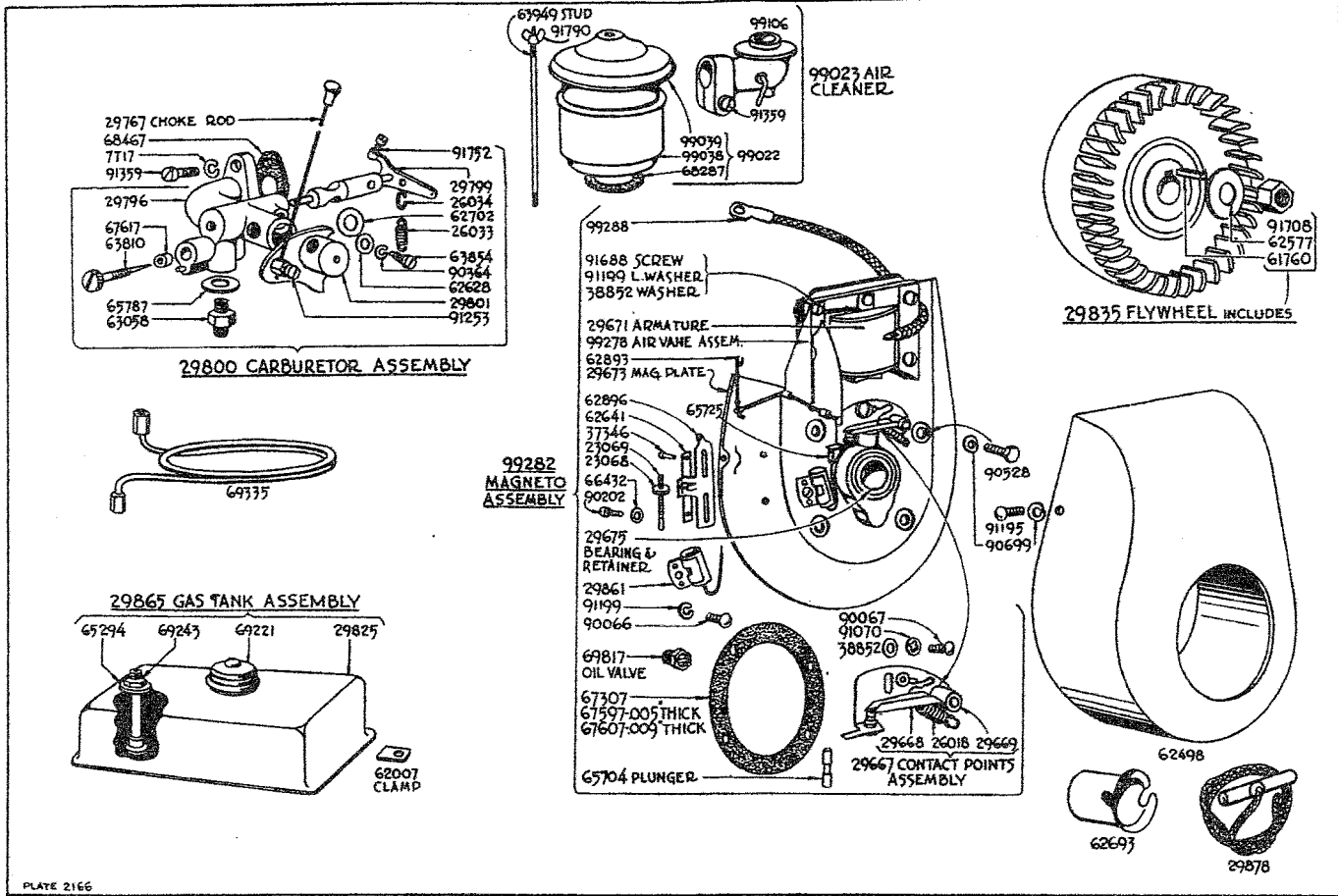

PLATE 2166

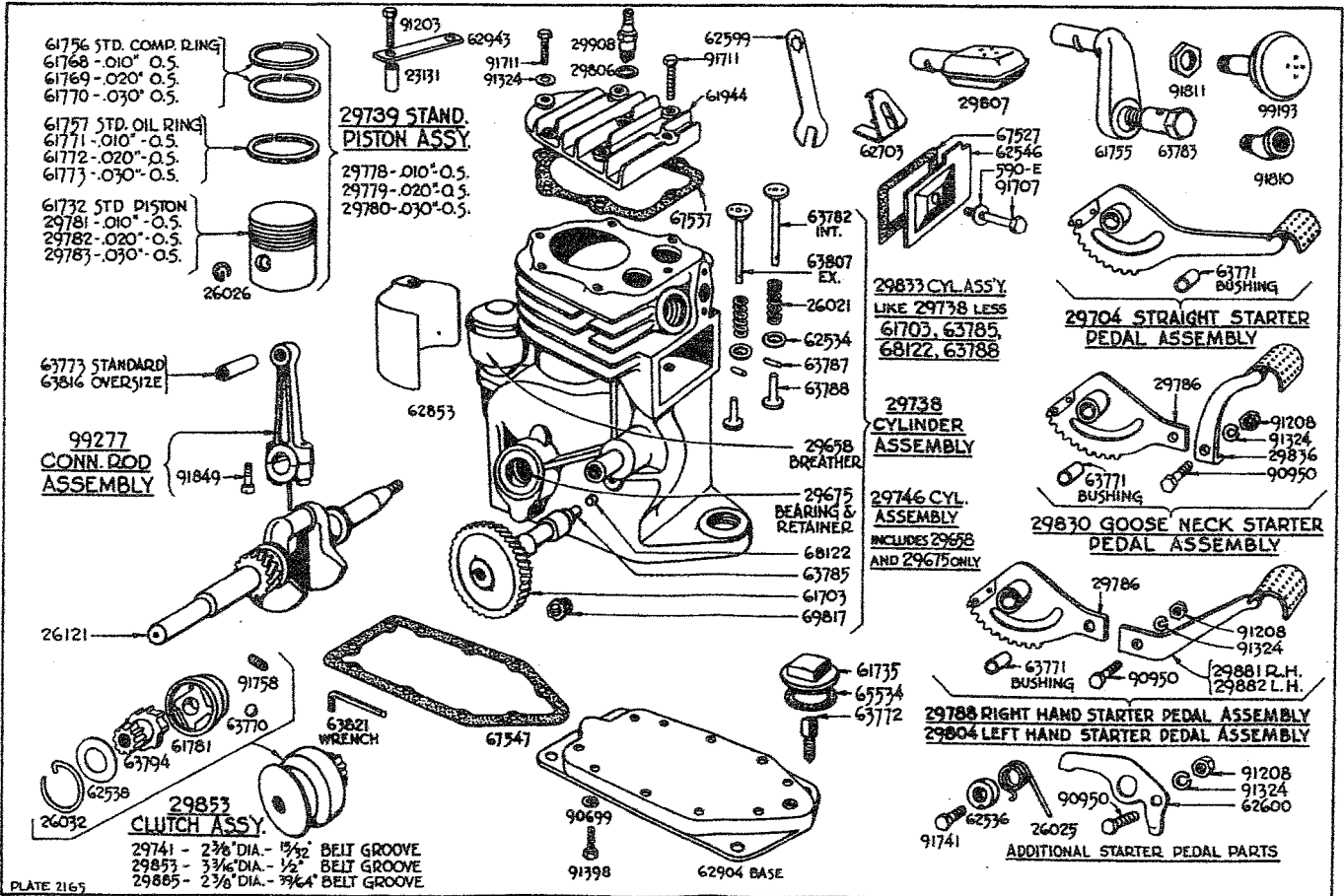

PLATE 2165

# Nation-Wide Service Organization

To provide prompt and efficient service on Briggs & Stratton motors. Authorized Central Service Distributors and Motor Service Stations are located in the principal cities of the United States and Canada.

Each Authorized Service Organization carries a complete stock of original Briggs & Stratton repair parts. Each is equipped with special factory service tools and factory-trained mechanics, assuring expert repair service on all Briggs & Stratton motors.

All Authorized Service Organizations are instructed by the factory to replace free of charge all parts found to be defective in either material or workmanship, according to the conditions of the Briggs & Stratton Guarantee.

All gratis work done under the guarantee is the responsibility of the Authorized Service Organization until all the material involved and supporting facts are submitted to and approved by the factory.

In a difference of opinion regarding a Service Organization's decision, their terms should be accepted and, either through them or direct, have all materials and supporting facts submitted to the factory for review.

Genuine Briggs & Stratton service will assure continuous motor satisfaction. Our long experience in motor maintenance prompts us to urge that all service work be done by an Authorized Service Organization or at our factory. Mechanics unfamiliar with Briggs & Stratton products, or without proper tools, should not be permitted to make major repairs.

Parts and repair work are F. O. B. Factory or any Authorized Briggs & Stratton Central Service Distributor, or Motor Service Station. The Central Service Distributor nearest you (see list below) will be glad to give you the name of our Motor Service Station in your locality. Space does not permit listing here.

## Authorized Central Service Distributors

STATE	CITY	NAME	LOCATION
Alabama	Birmingham	Birmingham Electric Battery Co.	Ave. B. at 23rd St.
Arizona	Phoenix	Motor Supply Co.	315 N. Central Ave.
California	Los Angeles	Electric Equipment Company	1611 S. Hope St.
California	San Francisco	Automotive Service Co.	930 Van Ness Ave.
Colorado	Denver	Spitzer Electrical Company	43 W. 9th Ave.
Florida	Jacksonville	Auto Electric & Carburetor Co.	40 W. Beaver St.
Florida	Miami	Electrical Equipment Co.	42-58 N. W. 4th St.
Florida	Tampa	Spencer Auto Electric, Inc.	807-11 E. Cass St.
Georgia	Atlanta	Auto Electric & Magneto Co.	477 Spring St., N. W.
Idaho	Boise	Bevens & Company	112 N. 12th St.
Illinois	Chicago	Mid-States Auto Electric Co.	2446 Indiana Ave.
Indiana	Indianapolis	Gulling Auto Electric Co.	450 N. Capitol Ave.
Iowa	Des Moines	Magneto Carburetor & Electric Co., Inc.	1308 Grand Ave.
Kansas	Wichita	The E. S. Cowie Electric Co.	230 S. Topeka Ave.
Kentucky	Lexington	Kentucky Ignition Co., Incorporated	Rose and Vine Sts.
Louisiana	New Orleans	Suhren, Inc.	1319 St. Charles Ave.
Louisiana	Shreveport	Chain Battery & Automotive Supply, Inc.	Marshall at Cotton Sts.
Massachusetts	Boston	Wm. H. Flaherty Co.	48-52 Cummington St.
Michigan	Detroit	Auto Electric & Service Corporation	90 Selden Ave.
Minnesota	Minneapolis	Reinhard Brothers Co., Inc.	11 S. Ninth St.
Missouri	Kansas City	The E. S. Cowie Electric Co.	1819 Wyandotte St.
Missouri	St. Louis	Medart Auto Electric Co., Inc.	3134 Washington Blvd.
Nebraska	Lincoln	Carl A. Anderson, Inc.	1637 P Street
Nebraska	Omaha	Carl A. Anderson, Inc.	16th and Jones St.
New York	Buffalo	The Battery & Starter Co., Inc.	681 Main St.
New York	New York	The Durham Co., Inc.	17 W. 60th St.
New York	Syracuse	The Durham Co., Inc.	601 W. Genesee St.
North Carolina	Charlotte	Carolina Rim & Wheel Co.	312 N. Graham St.
North Dakota	Fargo	Reinhard Bros., Inc.	109 Roberts St.
Ohio	Toledo	The Electric Power Maintenance Co.	26-30 Seventeenth St.
Oklahoma	Oklahoma City	American Electric Ignition Co.	725 N. Broadway
Oregon	Portland	Tracey & Co., Inc.	N. W. 10th and Glesan
Pennsylvania	Philadelphia	Auto Equipment & Service Co., Inc.	1522-24 Fairmount Ave.
Pennsylvania	Pittsburgh	Pitt Auto Electric Company	5135 Brum Blvd.
South Dakota	Aberdeen	Reinhard Brothers Co., Inc.	317 S. Lincoln St.
Tennessee	Knoxville	R. T. Clapp Company	401-7 N. Broadway
Tennessee	Memphis	Automotive Electric Service Co.	1095 Union Ave.
Texas	Amarillo	The E. S. Cowie Electric Co.	700 Van Buren St.
Texas	Dallas	Beard & Stone Electric Co., Inc.	2101 Bryan St.
Texas	El Paso	Motor Supply Co.	308 Chihuahua St.
Texas	Houston	Beard & Stone Electric Company, Inc.	Milam at Polk Ave.
Texas	San Antonio	S. X. Callahan	425 N. Flores St.
Utah	Salt Lake	Motor Equipment Company	605-609 So. State St.
Washington	Seattle	Sunset Electric Co.	300 Westlake North
Wisconsin	Milwaukee	Wisconsin Magneto Co.	918 N. Broadway

### DOMINION OF CANADA

Manitoba	Winnipeg	Beattie Auto Electric Limited	176 Fort St.
Ontario	Toronto-5	Auto Electric Service Company Limited	15 Breadalbane St.

**BRIGGS & STRATTON CORP.**  
MILWAUKEE, WIS., U. S. A.

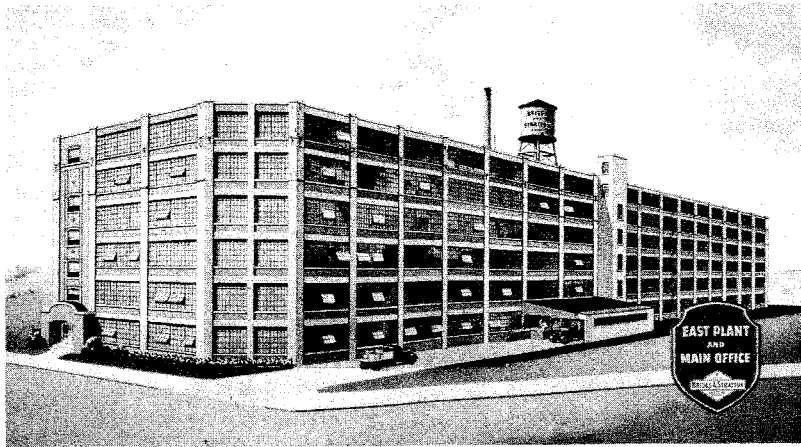

### WHERE BRIGGS AND STRATTON MOTORS ARE MADE

**T**HESE large and modern factory buildings, located in Milwaukee, Wisconsin, are complete with all modern equipment and machinery for precision construction, economical production, rigid inspection and thorough testing of Briggs & Stratton 4-cycle gasoline motors.

Briggs & Stratton Corp. produces more small 4-cycle air-cooled gasoline motors than any other manufacturer in the world.

